

# Static & Live Tooling

MAZAK LATHES

MULTIPLEX AND HYPER QUADREX HQR SERIES



# Special Live Tool Inquiry Form

Fax: (847) 367-4815  
Email: [inquiries@lyndexnikken.com](mailto:inquiries@lyndexnikken.com)

Fill in the form below and fax it to (847) 367-4815, or visit [www.lyndexnikken.com](http://www.lyndexnikken.com) and complete the form online. Lyndex-Nikken engineers will help you to determine the best live tool for your application.

Company \_\_\_\_\_ Name \_\_\_\_\_  
Address \_\_\_\_\_  
Zip \_\_\_\_\_ City \_\_\_\_\_  
Phone \_\_\_\_\_ E-mail \_\_\_\_\_

## Multiplex and Hyper Quadrex HQR Series

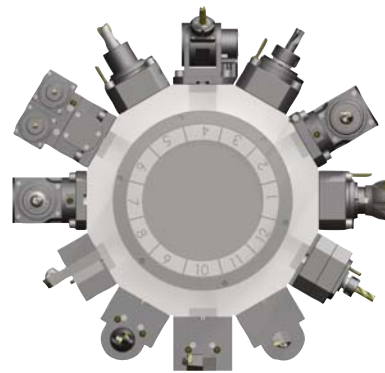
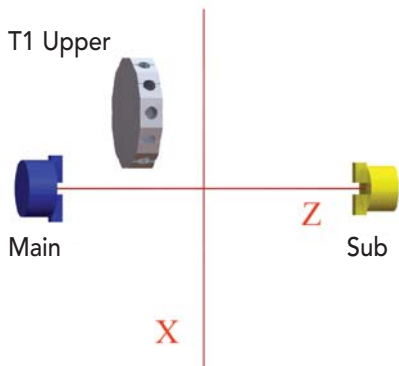

### Please specify design configuration:

- |                          |                          |                          |                          |
|--------------------------|--------------------------|--------------------------|--------------------------|
| <input type="checkbox"/> | <input type="checkbox"/> | <input type="checkbox"/> | <input type="checkbox"/> |
| <input type="checkbox"/> | <input type="checkbox"/> | <input type="checkbox"/> | <input type="checkbox"/> |

### Please specify holding system and cutting tool specifications:

#### Holding System

Preferred type of holding system (ER, Shrink Fit, Shell Mill Arbor, etc.): \_\_\_\_\_

#### Application and Cutting Tool Specifications

Type of material: \_\_\_\_\_

Type and nature of application (milling, drilling, reaming, slitting, etc.): \_\_\_\_\_

Size of cutter (diameter): \_\_\_\_\_ Overall length of cutter: \_\_\_\_\_

Flute length: \_\_\_\_\_ Requested RPM: \_\_\_\_\_ Requested torque: \_\_\_\_\_

#### Coolant Requirements

External/Internal: \_\_\_\_\_ Requested pressure capabilities: \_\_\_\_\_

2 Number of nozzle ports: \_\_\_\_\_ Coolant pipe design or configuration specifications: \_\_\_\_\_

# Table of Contents



## MAZAK STATIC & LIVE TOOLING

<i>Special Live Tool Inquiry Form</i>	2
<i>Table of Contents</i>	3
<i>Introduction</i>	4
<i>Features and Technology</i>	5
<i>Mazak Star-Type Turrets</i>	6
<i>Mazak Specifications and Part Numbering</i>	7
<i>Mimatic® MI: Modular Quick Change System</i>	8
<i>Live Tools for Mazak Multiplex 610/6100 &amp; Hyper Quadrex HQR-150</i>	9-17
<i>Static Tools for Mazak Multiplex 610/6100 &amp; Hyper Quadrex HQR-150</i>	18-19
<i>Live Tools for Mazak Multiplex 620/6200 &amp; Hyper Quadrex HQR-200</i>	20-28
<i>Static Tools for Mazak Multiplex 620/6200 &amp; Hyper Quadrex HQR-200</i>	29-30
<i>Live Tools for Mazak Multiplex 630/6300</i>	31-33
<i>Static Tools for Mazak Multiplex 630/6300</i>	34-35
<i>ER Series Collets and Tap Collets</i>	36-39
<i>Mimatic® MI Attachments</i>	40-44
<i>Torque Wrench, Wrench Usage, Warranty and Service</i>	45-46
<i>Accessories</i>	47

## Specials

Custom-made live tools can be engineered for your specific application. Please direct your request to our office (see special live tool inquiry form). Our engineering staff is ready to assist you with your specific tooling needs.



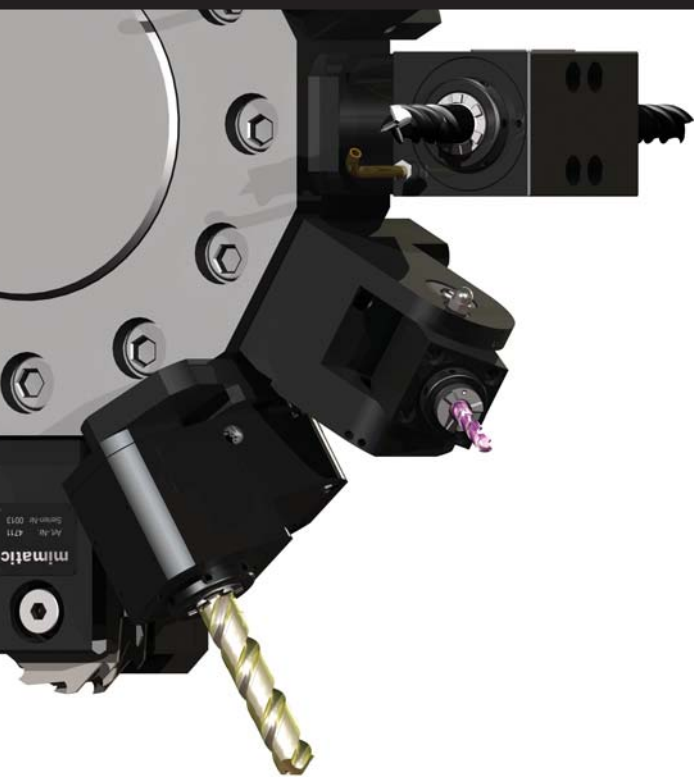

## Maximize the capabilities of your Mazak Machine

Mazak has selected Mimatic/Lyndex-Nikken live tools to ensure that peripheral equipment used on their lathes and machining centers is consistent both in terms of quality and performance.

Mimatic live tooling for Lyndex-Nikken offers the latest technology you can expect for turning operations. Designed and manufactured directly with Mazak engineers in Japan, our live tools have features and benefits unmatched by the competition. Gears, bearings, seals, every part is built to provide the highest accuracy, rigidity and stability.

With more than 30 years of tooling engineering and manufacturing experience, Lyndex-Nikken live tooling will maximize the capabilities of your machine, and keep you far ahead of the global competition. We understand that exceptional quality is key to your business. Let the manufacturers who share your philosophy in producing live tools join you in doing what you do best - machining the highest quality parts.

Enhanced with Mimatic/Lyndex-Nikken live tooling, your Mazak machine will allow you to reduce cycle times, eliminate extra operations and achieve maximum efficiency.

*Parts inventory, maintenance and repair, and rebuild services are available through Lyndex-Nikken.*

# Mazak

**LYNDEX  
NIKKEN** 

***Lyndex-Nikken is an official  
Mazak Qualified Peripherals  
supplier.***

**mimatic**<sup>®</sup>  
T o o l S y s t e m s

Lyndex-Nikken live tools are manufactured by Mimatic Tool Systems.



## FEATURES AND TECHNOLOGY

As an authorized OEM supplier to Mazak, Lyndex-Nikken live tools are designed and manufactured with highest precision and quality in Germany.

- **Drive Shafts and Spindles** - Made from the highest quality steel, all critical surface are precision ground and inspected to ensure highest concentricity.

- **Bearings** - High precision ABEC 7 or better spindle angular contact bearings for stronger axial loads.

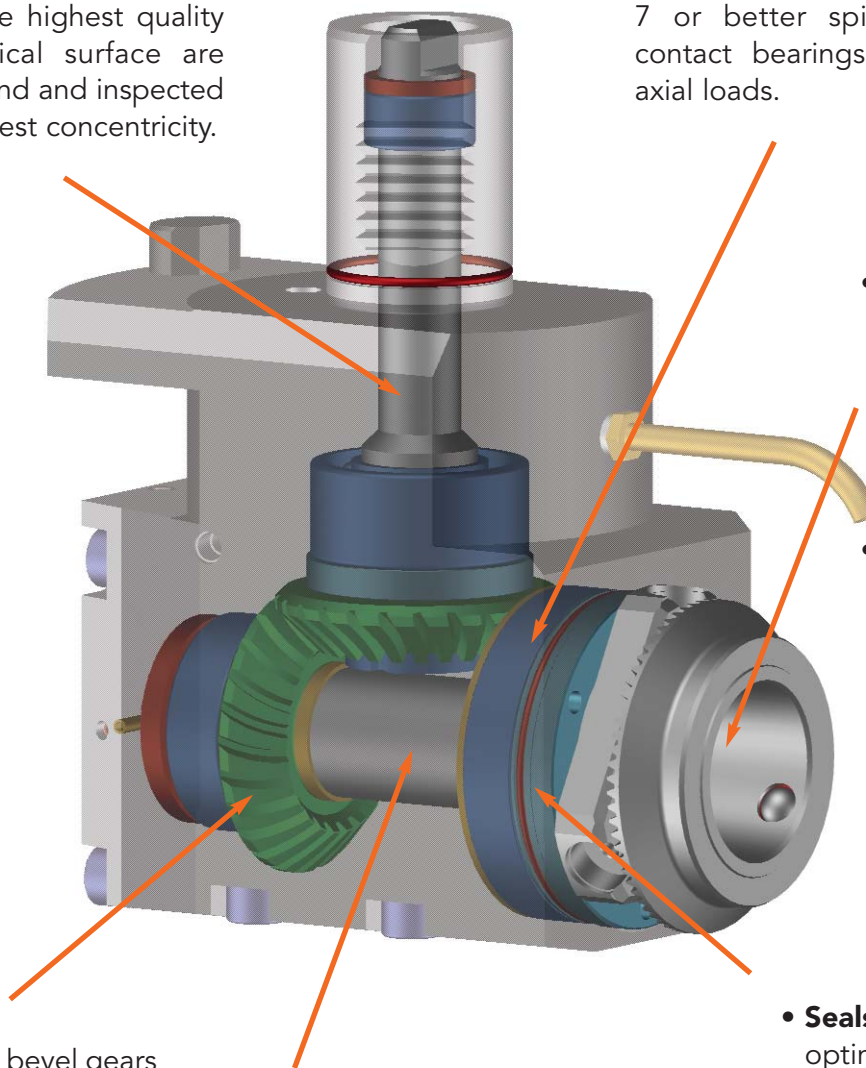

- **MI Quick Change System** - Mimatic's modular quick change system enables offline tool presetting and tools to be changed in seconds.

- **Recessed Collet Bore** - Recessed bore allows greater rigidity and longer tool projection.

- **Gears** - Helical bevel gears with Zykhlo-Paloid Helical tooth systems for better tooth contact and higher torque transmission.

- **Internal Coolant Capability** - 1000+ psi thru spindle coolant available for all models.

- **Seals** - Special PTFE friction optimized seals with labyrinth sealing system protect vital internal components from contamination.

## Guidelines for Operation with Mazak Turrets

**Tools are fixed on the revolver circuit.**

The orientation of the turret to the spindle is important.

Machines with Mazak turrets often come with a sub spindle.

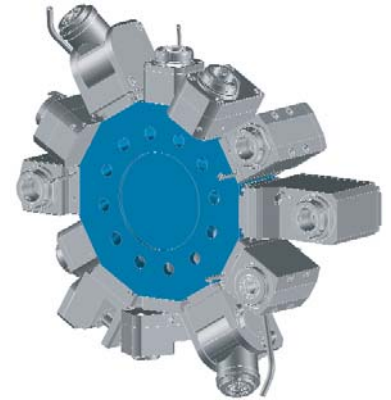

### Right- and left-hand versions on Mazak Turrets with Main- and Sub-Spindle

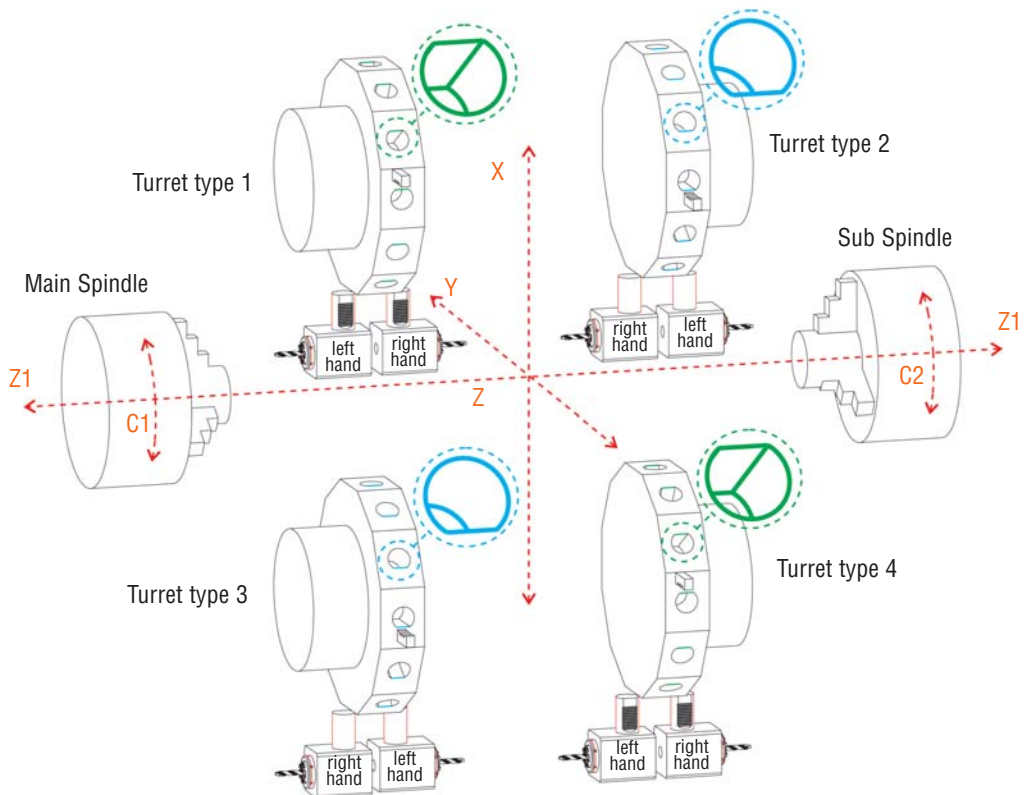

### Left-hand version

Please note dimension L1

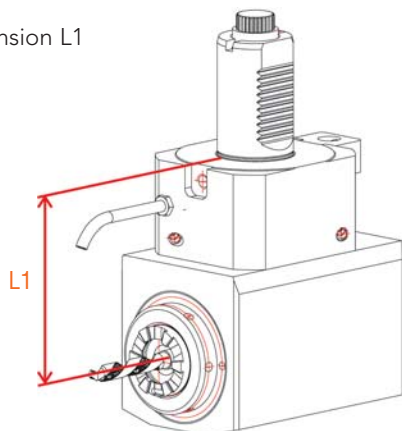

### Right-hand version

Please note dimension L1

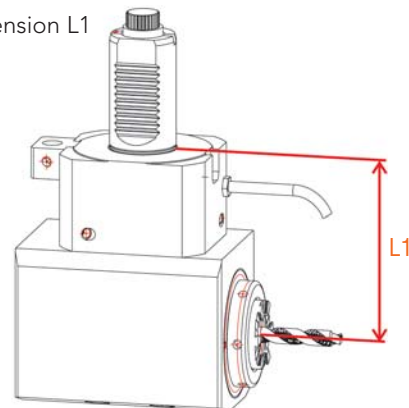

Please check interference circles with fixed tools.

## Mazak Multiplex Series and Hyper Quadrex Series

Machine type Series		Turret Stations
MP 610		12
MP 6100/6100	Y	16
MP 620	Y	12
MP 6200/6200	Y	12/16
MP 630		12
MP 6300/6300	Y	12
HQR 150	MSY	12
HQR 200	MSY	12

Machine type Series	F	SW	WL
Multiplex 610/6100 - HQR 150	596	286	155
Multiplex 620/6200 - HQR 200	680	320	180
Multiplex 630/6300	840	380	230

Interference Circles

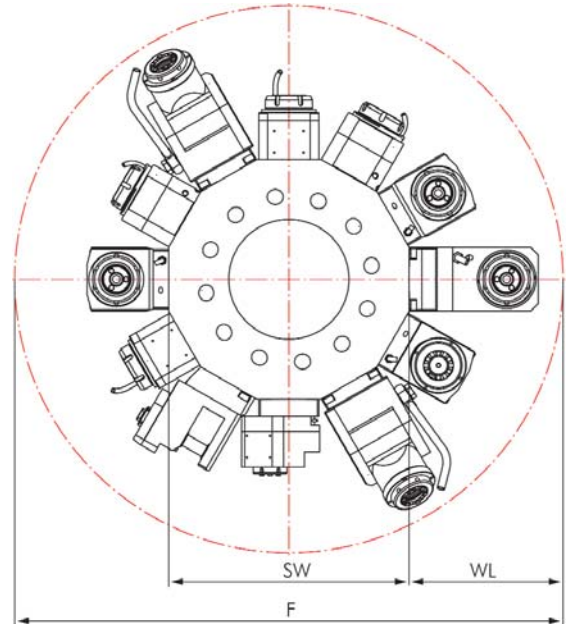

## Mazak Multiplex Part Numbering

Machine Make		Machine Model		Tool Nose / Output		Axis	Style		Speed / Torque		Coolant	
MZ		MP46		ER25		X	OFF		HS		C	
MZ	MAZAK	QT46	QTN VDI40 60mm (S)	ER16	ER16	x	OFF	Offset	HS	Hi-speed	C	Coolant
		QT47	QTN VDI40 70mm (S)	ER20	ER20	y	OFT	Offset Twin Spindle	HT	Hi-torque		
		QT5	QTN VDI50	ER25	ER25	z	OFG	Offset Quad	SP	Special		
		MP46	Multiplex VDI40 60mm	ER40	ER25	-	OFS	Offset Sub				
		MP47	Multiplex VDI40 70mm	SM1	SM1"	-	AD	Adjustable				
		MP5	Multiplex VDI50	SM75	SM3/4"	-	SUB	Sub spindle				
		CT12	Cybertech 12 station	SM12	SM1.1/4"	-	MS	Main Sub Opposite	2 Spindles Total			
		BG75	Boring 3/4"	-	MD	Main Dual	4 Spindles Total					
		BG10	Boring 1"	-	MSD	Main Sub Dual	3 Spindles Total					
		BG12	Boring 1.1/4"	-	MT	Main Triple	6 Spindles Total					
		BG15	Boring 1.1/2"	-	MST	Main Sub Triple	4 Spindles Total					
		BG20	Boring 2"	-	MQ	Main Quad	8 Spindles Total					
		ID12	ID holder 1.25"	-	MSQ	Main Sub Quad						
		ID15	ID holder 1.50"	-								
		OD10	OD holder 1"	-								
		SB22	Saw blade D=22	-								
		CT40	CAT40	-								
		MI40	MI40	-								
		MI50	MI50	-								
		MI63	MI63	-								

## Mimatic® MI: Modular Quick Change System

The Mimatic® MI interface is a very innovative modular quick change system that allows to reduce machine downtimes because all units can be preset outside the machine.

### Advantages

- Universal tool clamping system for all production areas
- Presetting of the tools off-line by length adjustment screw
- Tool change within seconds
- Concentricity of the interface < 0.002mm
- Secure holding force by form-locking
- Very short design
- Different size toolholders available
- All toolholders with internal coolant

### Can be used on CNC-Turning Machines and Machining Centers

Driven toolholders for all turning machines, machining centers, milling machines, turn/mill centers as well as transfer and special machines. Driven toolholders are available in many different versions:

- Shafts such as VDI, BT, CAT, HSK, Capto...
- Straight and angle units
- Single or multi-spindle versions
- Gear multiplication or reduction
- Internal and/or external coolant supply
- Central or offset

### Modular toolholders available in different sizes for all production areas

- Tapping toolholders
- Collet toolholders (internal and external nut)
- Hydro-flex hydraulic toolholders
- Thread tightening toolholder cutters
- Morse taper shank toolholders
- Weldon and whistle notch toolholders
- Shell mill toolholders

All toolholders are available for use with your presetter.

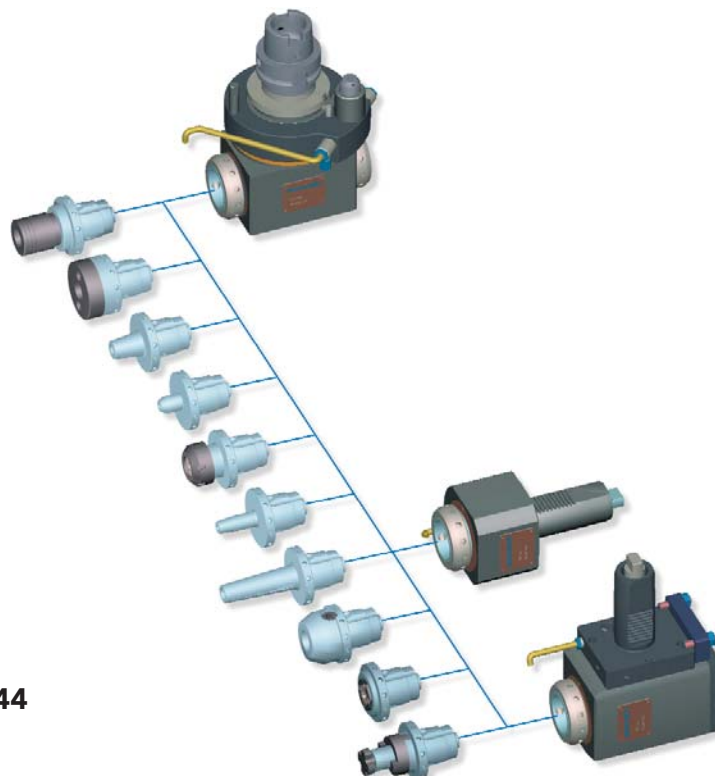

Please refer to pages 40 - 44 for MI attachments details and part numbers.



## ER32 Offset Type

Part #: MZMP46-ER32X-OFF

Mimatic Part #(old): 05.0411.7142.505  
Mimatic Part #(new): 124018

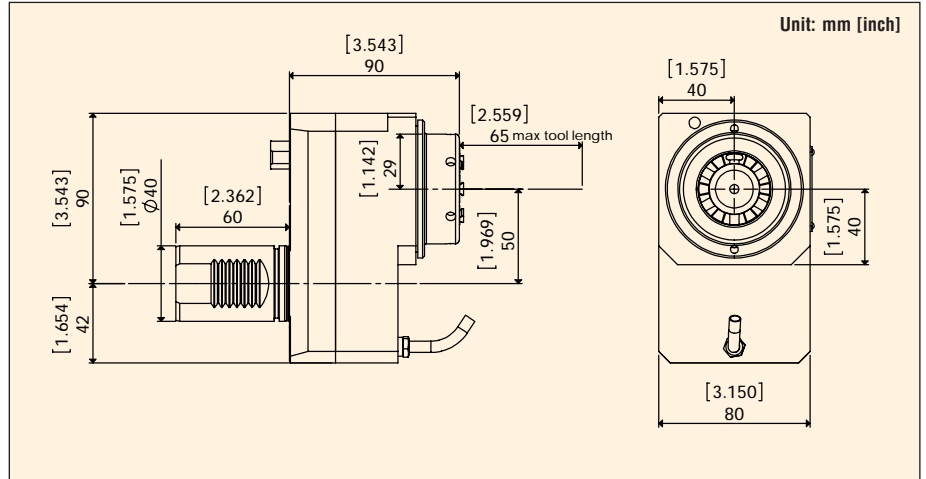

Collet Size	Clamping Range	Max. Torque Nm (ft/lbs)	Input/Output RPM (Max.)	Gear Ratio	Input/Output Rotation	Coolant	Spindle Wrench	Nut Wrench
ER32	1-20mm	50 (36.8)	6500/6500	1:1	CW-CCW	External	107642	112900

Please refer to pages 36 - 39 for ER Series Collets and ER Tap Collets details. Wrenches not included with holder.

## ER32 Offset Type

Part #: MZMP46-ER32X-OFF-C

Mimatic Part #(old): 05.0611.7142.505  
Mimatic Part #(new): 124252

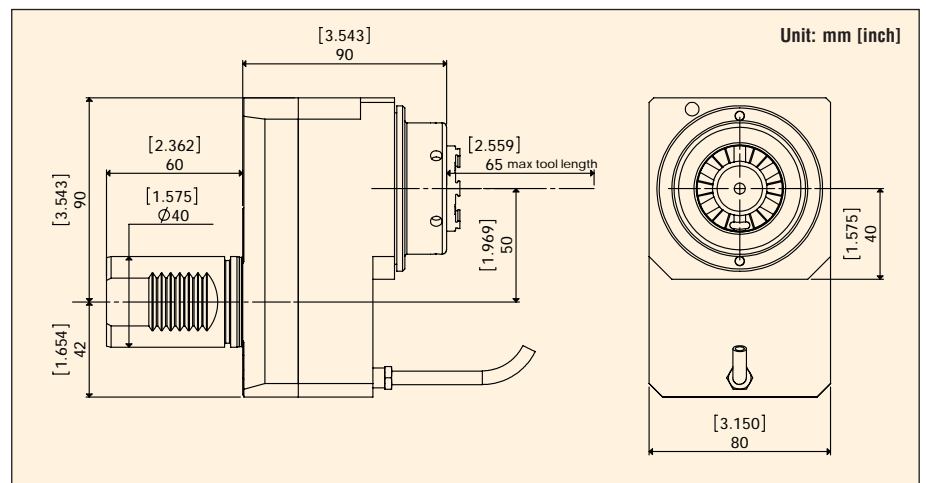
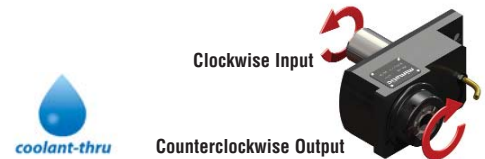

Collet Size	Clamping Range	Max. Torque Nm (ft/lbs)	Input/Output RPM (Max.)	Gear Ratio	Input/Output Rotation	Coolant	Spindle Wrench	Nut Wrench
ER32	1-20mm	50 (36.8)	6500/6500	1:1	CW-CCW	Internal (1000 PSI)	107642	112900

Please refer to pages 36 - 39 for ER Series Collets and ER Tap Collets details. Wrenches not included with holder. **Internal coolant tools must not be run dry.**

## ER25 Offset Type

Part #: MZMP46-ER25X-OFF-HS

Mimatic Part #(old): 05.0412.7142.404  
Mimatic Part #(new): 124064

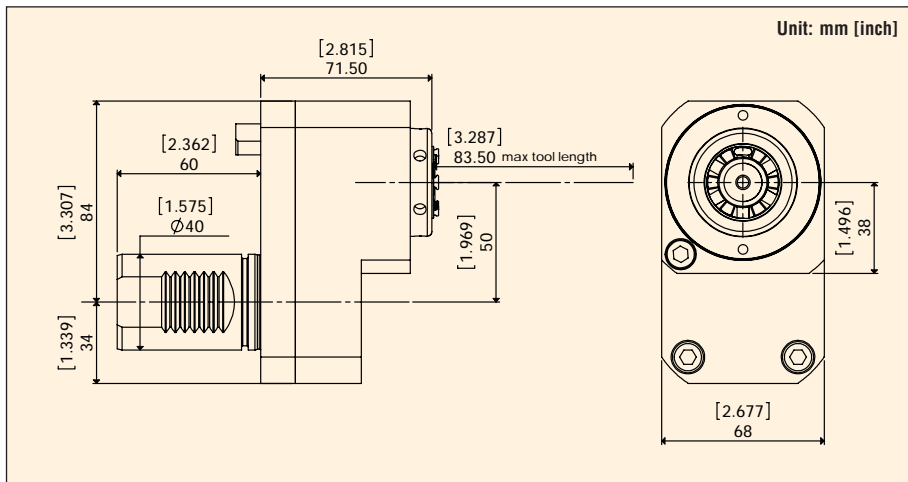

Collet Size	Clamping Range	Max. Torque Nm (ft/lbs)	Input/Output RPM (Max.)	Gear Ratio	Input/Output Rotation	Coolant	Spindle Wrench	Nut Wrench
ER25	0.5-16 mm	25 (18.4)	6500/13000	1:2	CW-CW	External	107446	112913

Please refer to pages 36 - 39 for ER Series Collets and ER Tap Collets details. Wrenches not included with holder.

## ER25 Offset Type

Part #: MZMP46-ER25X-OFF-HSC

Mimatic Part #(old): 05.0612.7142.404HD  
Mimatic Part #(new): 124342

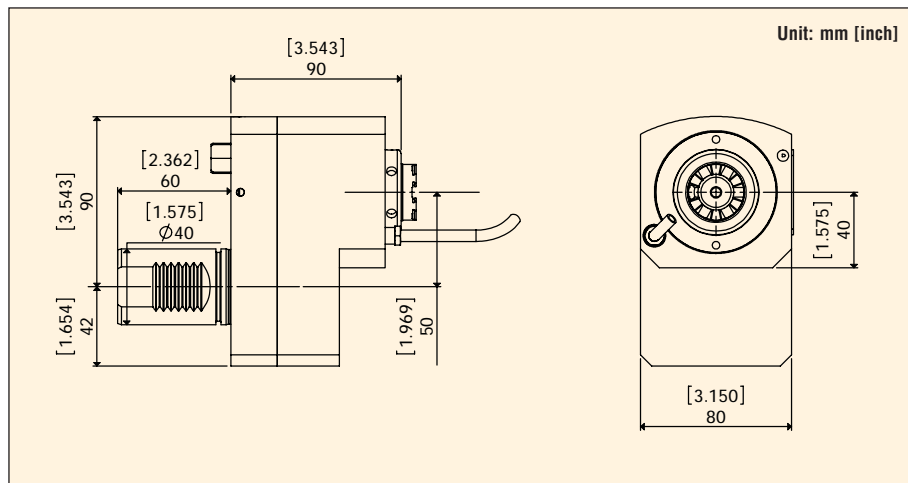
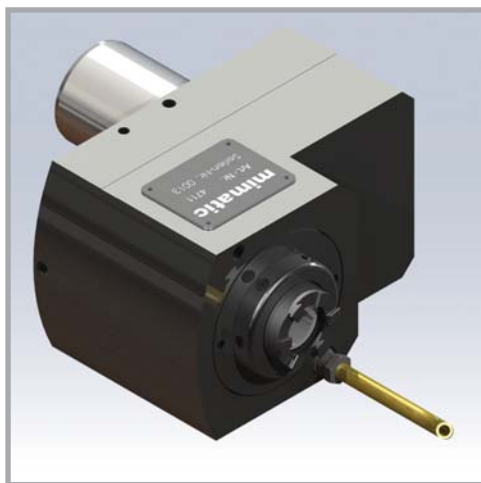

Collet Size	Clamping Range	Max. Torque Nm (ft/lbs)	Input/Output RPM (Max.)	Gear Ratio	Input/Output Rotation	Coolant	Spindle Wrench	Nut Wrench
ER25	0.5-16mm	25 (18.4)	6500/13000	1:2	CW-CCW	Internal (1000 PSI)	107446	112913

Please refer to pages 36 - 39 for ER Series Collets and ER Tap Collets details. Wrenches not included with holder. Internal coolant tools must not be run dry.

## ER25 Offset Type

Part #: MZMP46-ER25X-OFF-C

Mimatic Part #(old): 05.0211.7140.404  
Mimatic Part #(new): 123681



Clockwise Input

Counterclockwise Output

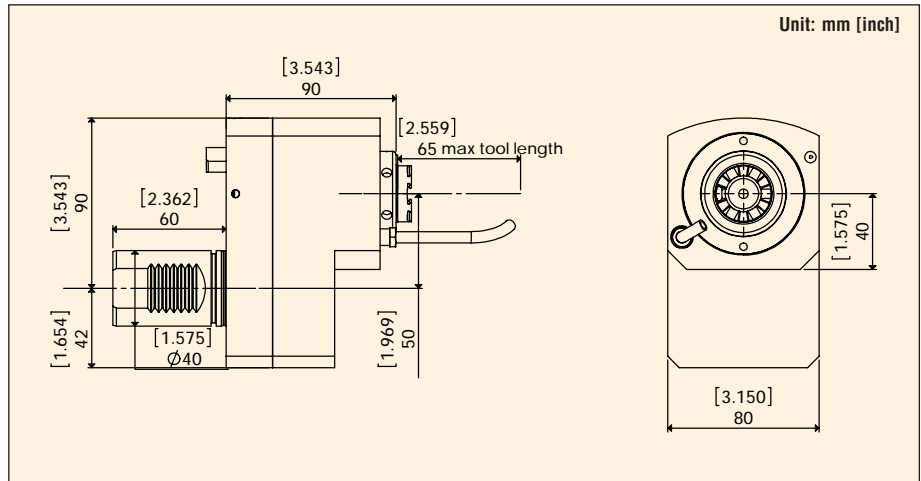

Collet Size	Clamping Range	Max. Torque Nm (ft/lbs)	Input/Output RPM (Max.)	Gear Ratio	Input/Output Rotation	Coolant	Spindle Wrench	Nut Wrench
ER25	0.5-16 mm	25 (18.4)	6500/6500	1:1	CW-CCW	Internal (1000 PSI)	107446	112913

Please refer to pages 36 - 39 for ER Series Collets and ER Tap Collets details. Wrenches not included with holder. **Internal coolant tools must not be run dry.**

## MI50 Offset Type

Part #: MZMP46-MI50X-OFF

Mimatic Part #(old): 05.0411.7140.MI50  
Mimatic Part #(new): 124013

Clockwise Input

Counterclockwise Output

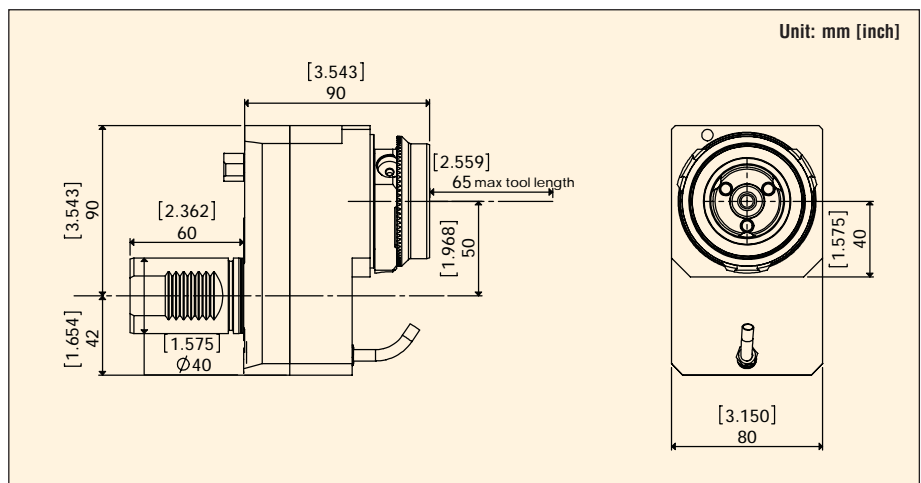

Collet Size	Clamping Range	Max. Torque Nm (ft/lbs)	Input/Output RPM (Max.)	Gear Ratio	Input/Output Rotation	Coolant	Spindle Wrench
MI50	-	50 (36.8)	6500/6500	1:1	CW-CCW	External	170419

Please refer to pages 40 - 44 for MI attachments details. Wrenches not included with holder.

## MI50 Offset Type

Part #: MZMP46-MI50X-OFF-C

Mimatic Part #(old): 05.0211.7140.MI50  
Mimatic Part #(new): 123683



Clockwise Input

Counterclockwise Output

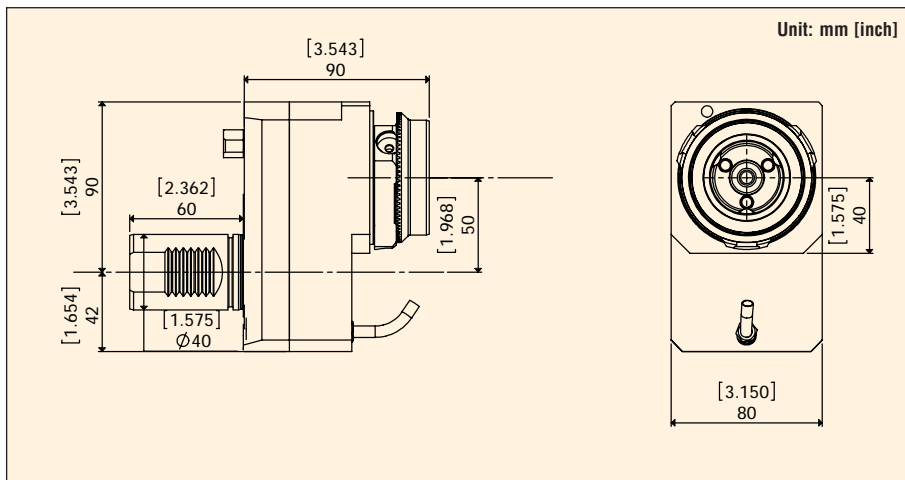

Collet Size	Clamping Range	Max. Torque Nm (ft/lbs)	Input/Output RPM (Max.)	Gear Ratio	Input/Output Rotation	Coolant	Spindle Wrench
MI50	-	50 (36.8)	6500/6500	1:1	CW-CCW	Internal (1000 PSI)	170419

Please refer to pages 40 - 44 for MI attachments details. Wrenches not included with holder. Internal coolant tools must not be run dry.

## ER32 90 Degree Angle

Part #: MZMP46-ER32Z

Mimatic Part #(old): 05.1311.7140.505  
Mimatic Part #(new): 124610

Clockwise Input

Counterclockwise Output

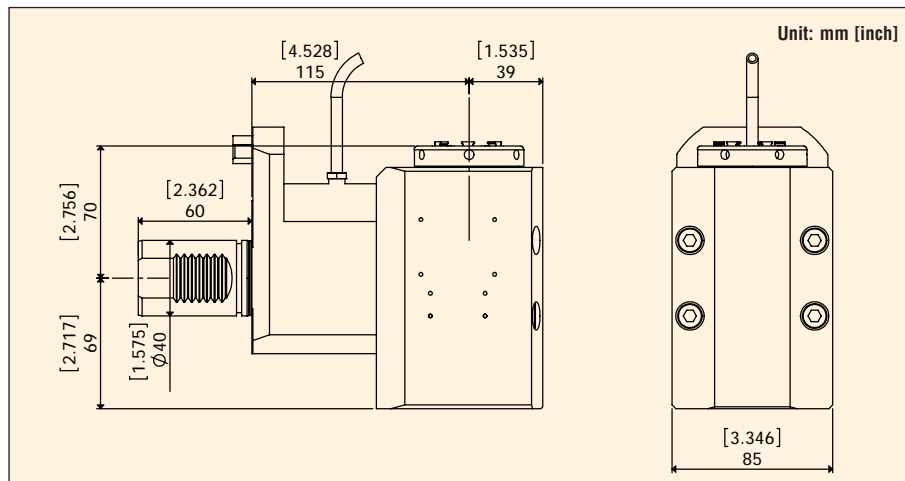

Collet Size	Clamping Range	Max. Torque Nm (ft/lbs)	Input/Output RPM (Max.)	Gear Ratio	Input/Output Rotation	Coolant	Spindle Wrench	Nut Wrench
ER32	1-20mm	50 (36.8)	6500/6500	1:1	CW-CCW	External	107642	112900

Please refer to pages 36 - 39 for ER Series Collets and ER Tap Collets details. Wrenches not included with holder.



## ER32 90 Degree Angle

Part #: MZMP46-ER32Z-C

Mimatic Part # (l d): 05.1611.7140.505  
Mimatic Part # (e w): 124854

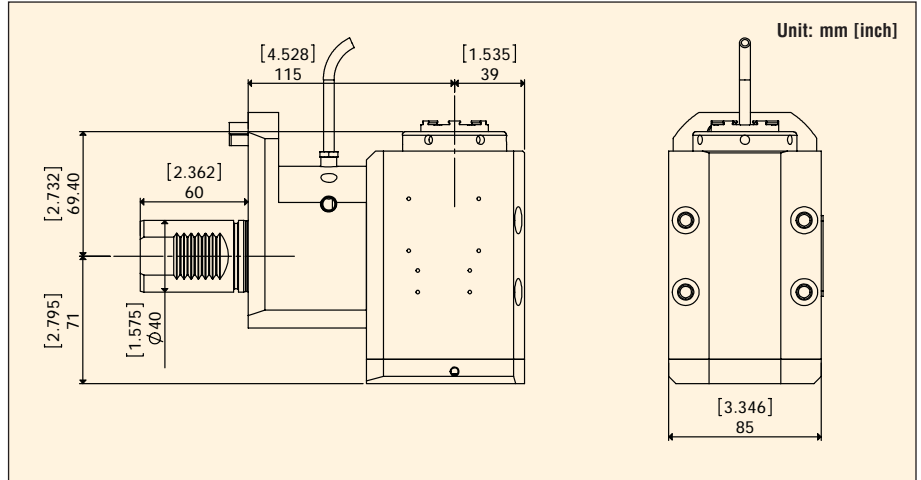
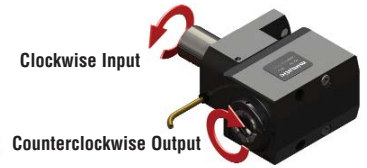

Collet Size	Clamping Range	Max. Torque Nm (ft/lbs)	Input/Output RPM (Max.)	Gear Ratio	Input/Output Rotation	Coolant	Spindle Wrench	Nut Wrench
ER32	1-20mm	50 (36.8)	6500/6500	11	CW-CCW	Internal (1000 PSI)	107642	112900

Please refer to pages 36 - 39 for ER Series Collets and ER Tap Collets details. Wrenches not included with holder. **Internal coolant tools must not be run dry.**

## ER25 90 Degree Angle

Part # MZMP46-ER25Z-HS

Mimatic Part # (l d): 05.1312.7140.504  
Mimatic Part # (e w): 124689

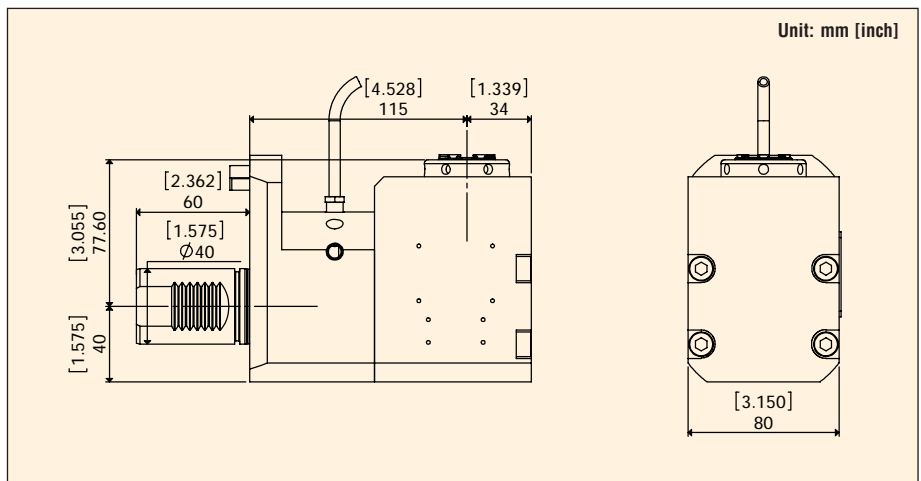
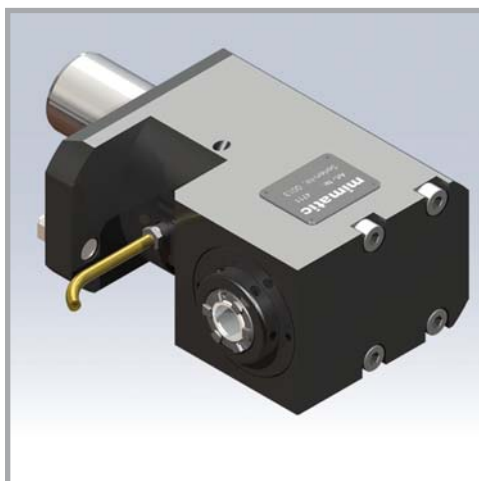
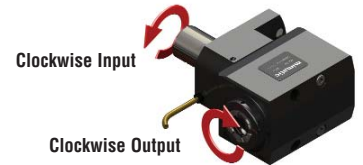

Collet Size	Clamping Range	Max. Torque Nm (ft/lbs)	Input/Output RPM (Max.)	Gear Ratio	Input/Output Rotation	Coolant	Spindle Wrench	Nut Wrench
ER25	0.5-16mm	25 (18.4)	6500/13000	12	CW-CW	External	107446	112913

Please refer to pages 36 - 39 for ER Series Collets and ER Tap Collets details. Wrenches not included with holder.

## MI50 90 Degree Angle

Part #: MZMP46-MI50Z-C

Mimatic Part #(old): 05.1611.7140.MI50  
Mimatic Part #(new): 124856

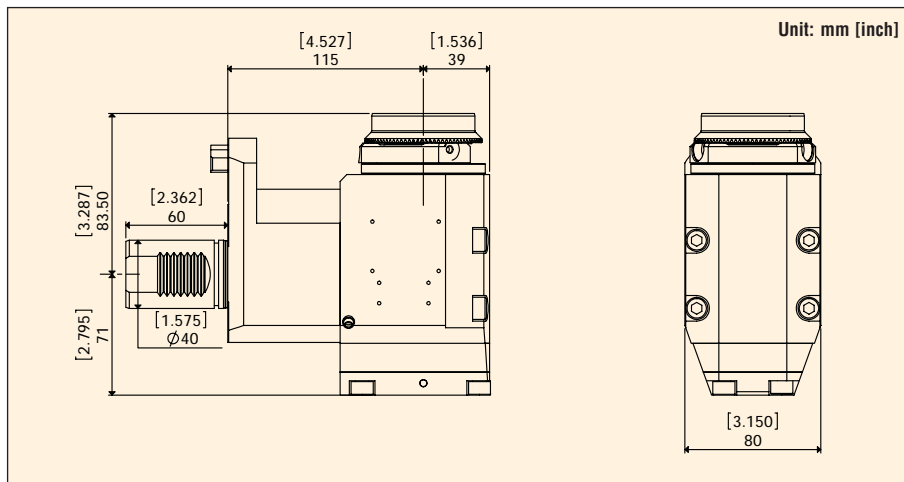
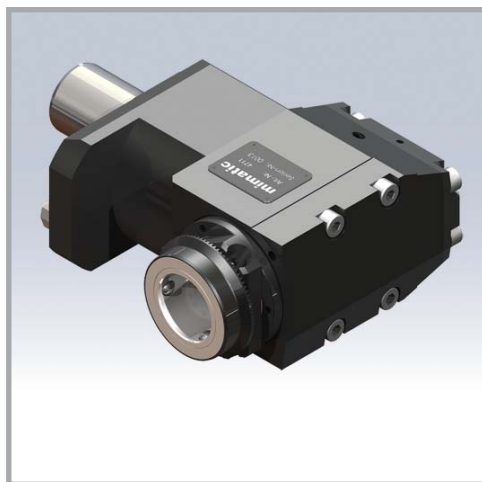
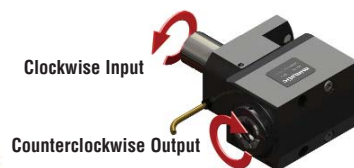

Collet Size	Clamping Range	Max. Torque Nm (ft/lbs)	Input/Output RPM (Max.)	Gear Ratio	Input/Output Rotation	Coolant	Spindle Wrench
MI50	-	50 (36.8)	6500/6500	1:1	CW-CCW	Internal (1000 PSI)	170419

Please refer to pages 40 - 44 for MI attachments details. Wrenches not included with holder. **Internal coolant tools must not be run dry.**

## MI40 90 Degree Angle

Part #: MZMP46-MI40Z-HS

Mimatic Part #(old): 05.1312.7140.MI40  
Mimatic Part #(new): 170167

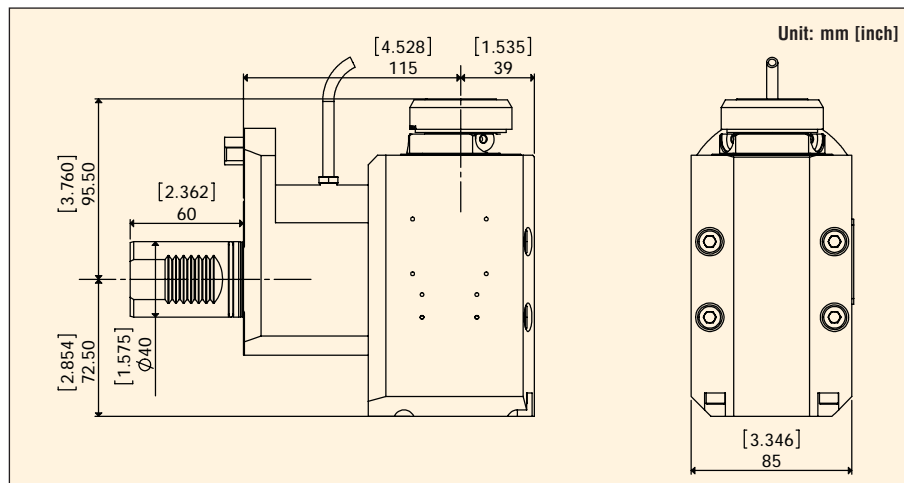
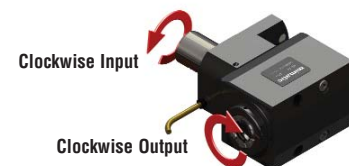

Collet Size	Clamping Range	Max. Torque Nm (ft/lbs)	Input/Output RPM (Max.)	Gear Ratio	Input/Output Rotation	Coolant	Spindle Wrench
MI40	-	25 (18.4)	6500/13000	1:2	CW-CW	External	170734

Please refer to pages 40 - 44 for MI attachments details. Wrenches not included with holder.

## MI40 90 Degree Angle

Part #: MZMP46-MI40Z-HSC

Mimatic Part #(old): 05.1312.7140.MI40  
Mimatic Part #(new): 124915

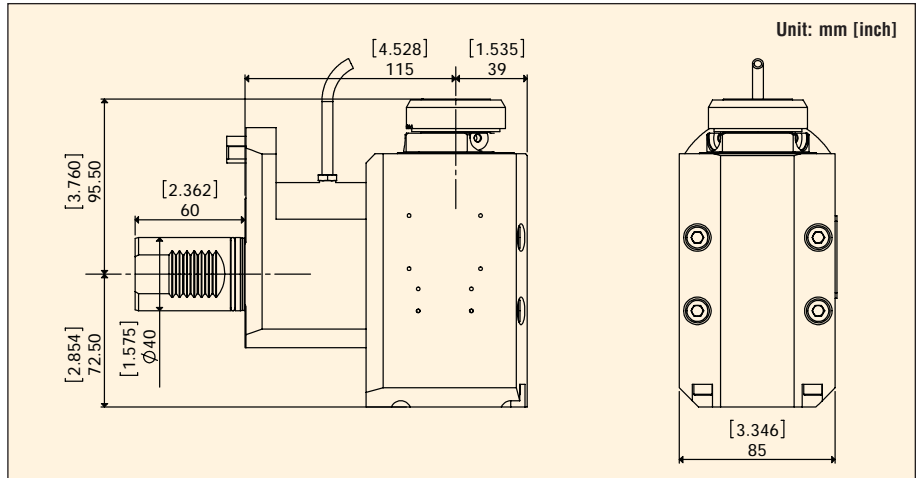
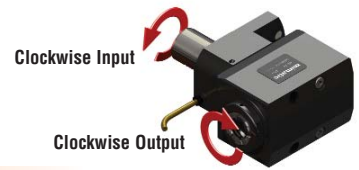

Collet Size	Clamping Range	Max. Torque Nm (ft/lbs)	Input/Output RPM (Max.)	Gear Ratio	Input/Output Rotation	Coolant	Spindle Wrench
MI40	-	25 (18.4)	6500/13000	1:2	CW-CW	Internal (1000 PSI)	170734

Please refer to pages 40 - 44 for MI attachments details. Wrenches not included with holder. Internal coolant tools must not be run dry.

## ER16 Angle-Unit Adjustable

Part #: MZMP46-ER16-AD

Mimatic Part #(old): 05.1911.7140.402  
Mimatic Part #(new): 125024

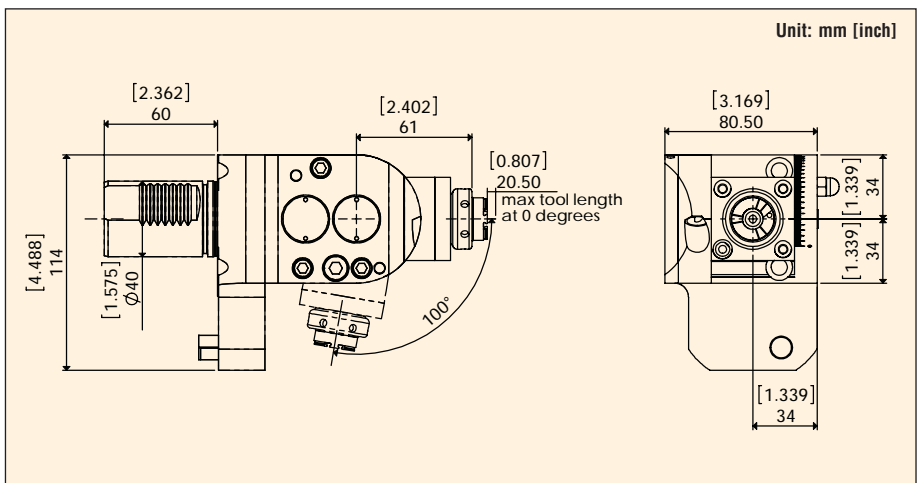
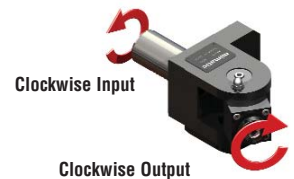

Collet Size	Clamping Range	Max. Torque Nm (ft/lbs)	Input/Output RPM (Max.)	Gear Ratio	Input/Output Rotation	Coolant	Spindle Wrench	Nut Wrench
ER16	0.5-10mm	6 (4.4)	6500/6500	1:1	CW-CW	External	107557	112954

Please refer to pages 36 - 39 for ER Series Collets and ER Tap Collets details. Wrenches not included with holder.

## ER16 Angle-Unit Adjustable

Part #: MZMP46-ER16-AD-HS

Mimatic Part #(old): 05.1914.7140.402  
Mimatic Part #(new): 125051

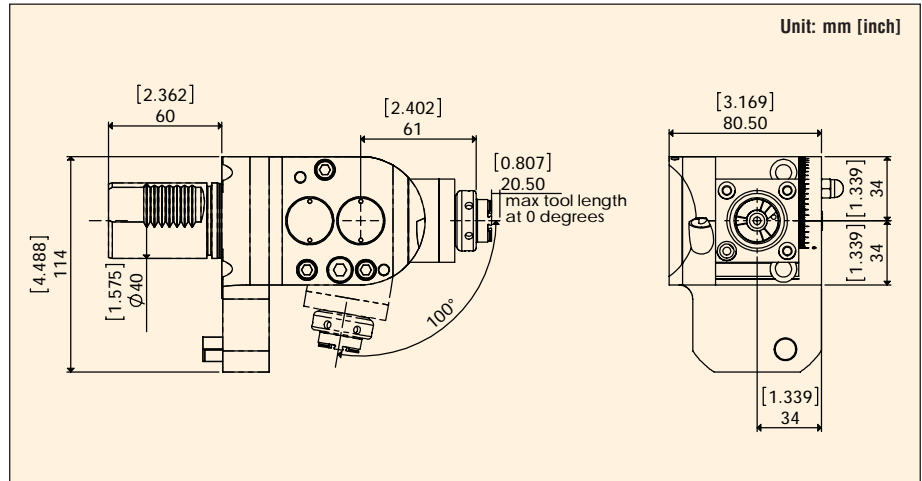
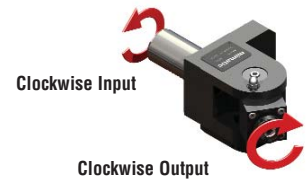

Collet Size	Clamping Range	Max. Torque Nm (ft/lbs)	Input/Output RPM (Max.)	Gear Ratio	Input/Output Rotation	Coolant	Spindle Wrench	Nut Wrench
ER16	0.5-10mm	6 (4.4)	3750/15000	1:4	CW-CW	External	107557	112954

Please refer to pages 36 - 39 for ER Series Collets and ER Tap Collets details. Wrenches not included with holder.

## ER25 Y-Unit Adjustable

Part #: MZMP46-ER25Y-AD

Mimatic Part #(old): 05.0511.7142.404  
Mimatic Part #(new): 124114

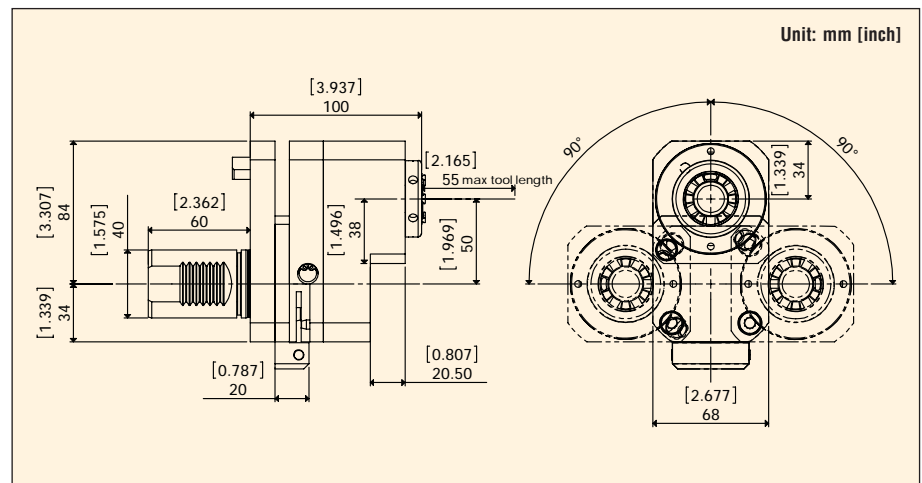
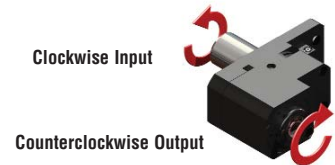

Collet Size	Clamping Range	Max. Torque Nm (ft/lbs)	Input/Output RPM (Max.)	Gear Ratio	Input/Output Rotation	Coolant	Spindle Wrench	Nut Wrench
ER25	0.5-16mm	25 (18.4)	6500/6500	1:1	CW-CCW	External	107446	112913

Please refer to pages 36 - 39 for ER Series Collets and ER Tap Collets details. Wrenches not included with holder.



## MI40 Y-Unit Adjustable

Part #: MZMP46-MI40Y-AD

Mimatic Part #(old): 05.35131.7140  
Mimatic Part #(new): 169223

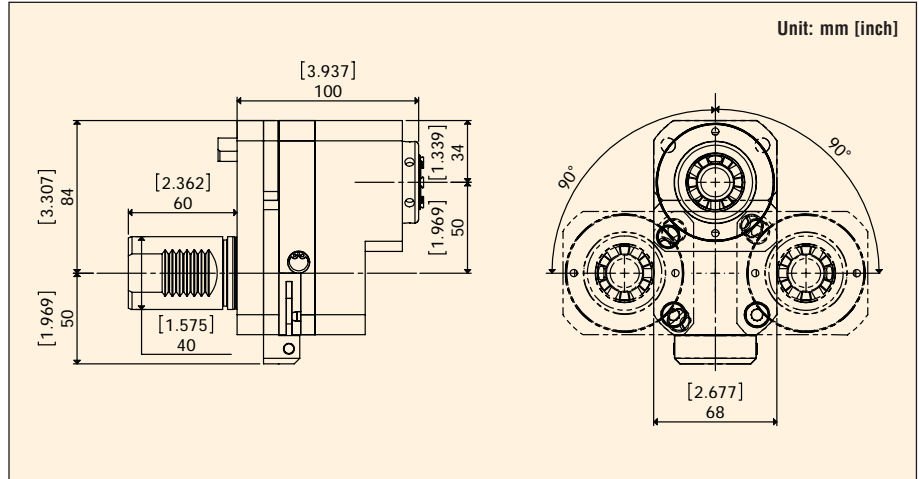
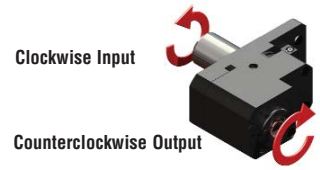

Collet Size	Clamping Range	Max. Torque Nm (ft/lbs)	Input/Output RPM (Max.)	Gear Ratio	Input/Output Rotation	Coolant	Spindle Wrench
MI40	-	25 (18.4)	6500/6500	1:1	CW-CCW	External	170734

Please refer to pages 40 - 44 for MI attachments details. +/- 50mm Y axis adjustment. Wrenches not included with holder.

## Saw Blade Holder - 16mm

Part #: MZMP46-SB22X

Mimatic Part #(old): 05.35131.7140  
Mimatic Part #(new): 125101

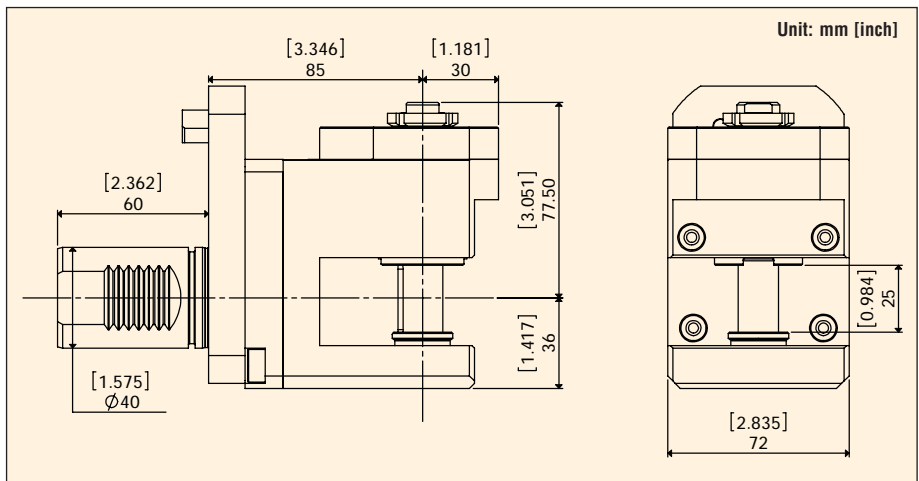
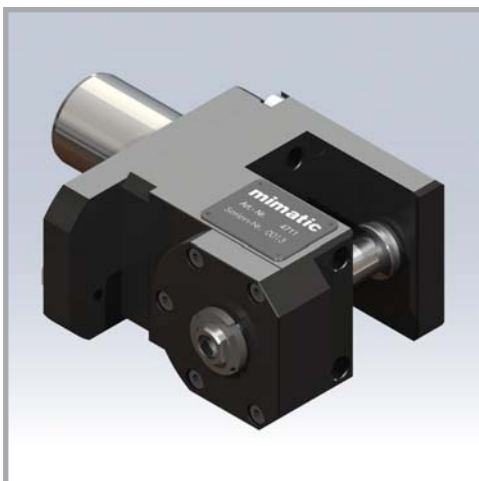
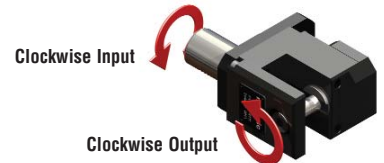

Collet Size	Clamping Range	Max. Torque Nm (ft/lbs)	Input/Output RPM (Max.)	Gear Ratio	Input/Output Rotation	Coolant	Spindle Wrench	Nut Wrench
16mm arbor	-	20 (14.7)	6500/2450	2.66:1	CW-CW	External	-	-

Inch size arbor available.

# Combination Holder

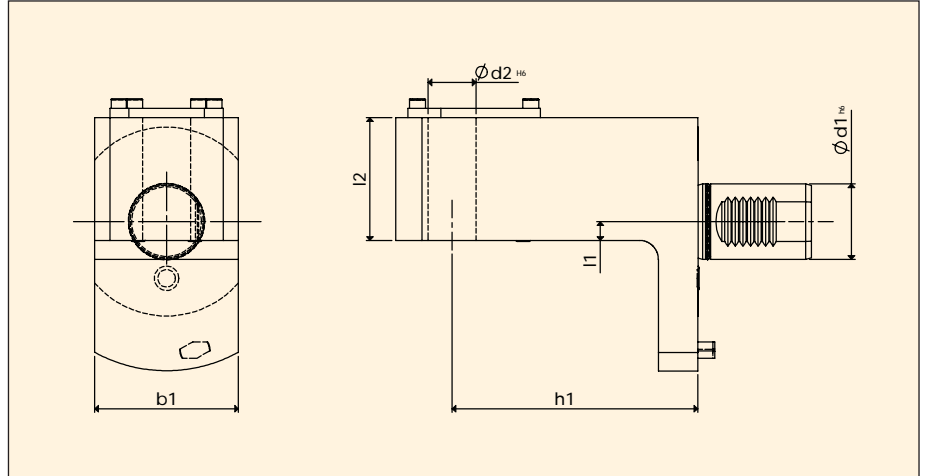

Lyndex-Nikken Part Number	Mimatic Part# (new)	Size	d1	d2	l1	l2	b1	h1
MZMP46-BG10Z-C	104088	VDI 40	1.575	1.000	0.394	2.559	2.992	5.118
MZMP46-BG12Z-C	117963	VDI 40	1.575	1.250	0.394	2.559	2.992	5.118
MZMP46-BG15Z-C	174945	VDI 40	1.575	1.500	0.394	2.559	2.992	5.118

Metric sizes available. Tool can be used for coolant kub drills.

# OD Turning Tool

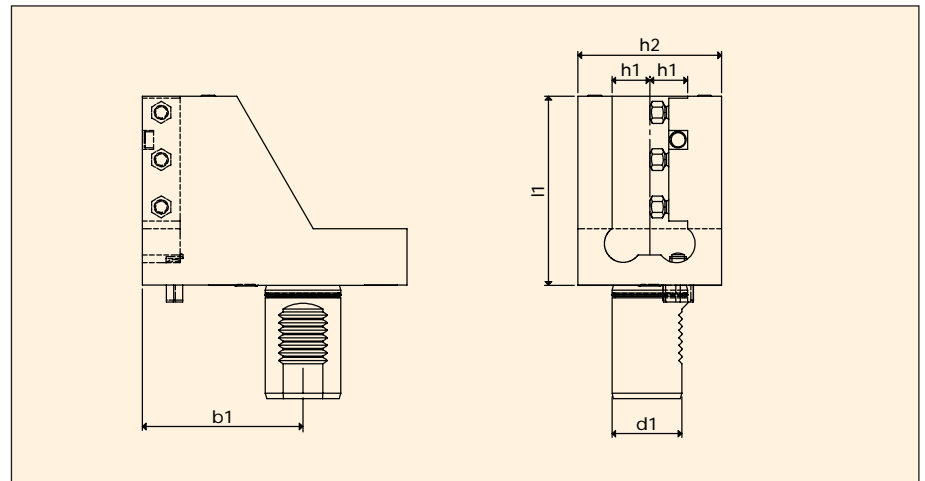
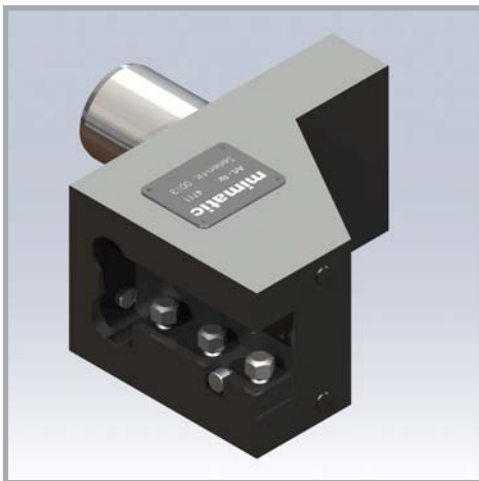

Lyndex-Nikken Part Number	Mimatic Part# (new)	Size	d1	l1	h2	b1	h1
MZMP46-OD75X	174958	VDI 40	1.575	3.937	2.992	3.346	0.750

Right hand and left hand reversible.

MP 610/6100 & HQR-150

# Face Turning

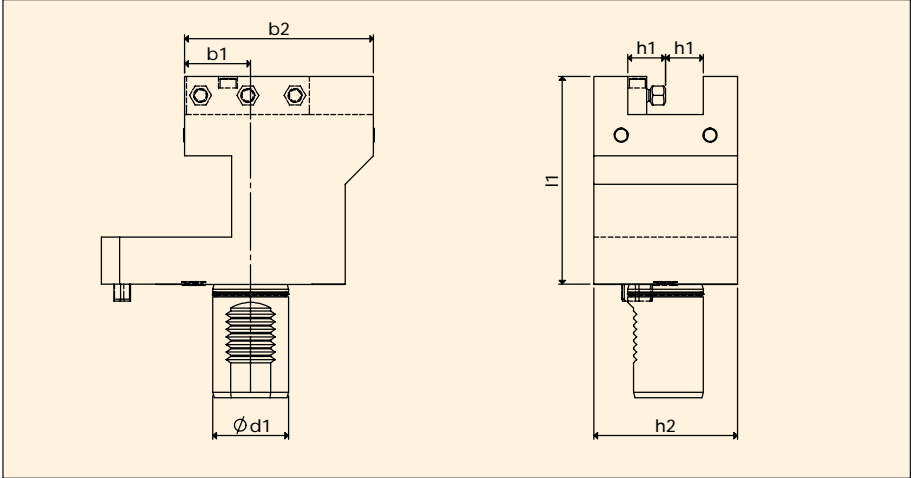

Lyndex-Nikken Part Number	Mimatic Part# (new)	Size	d1	b2	l1	h2	b1	h1
MZMP46-ID75Z	174956	VDI 40	1.575	3.937	4.331	2.992	1.378	0.750

Right hand and left hand reversible.

## ER32 Offset Type

Part # MZMP47-ER32X-OFF

Mimatic Part # (l d): 05.0411.7143.505  
Mimatic Part # (e w): 124021

Clockwise Input

Counterclockwise Output

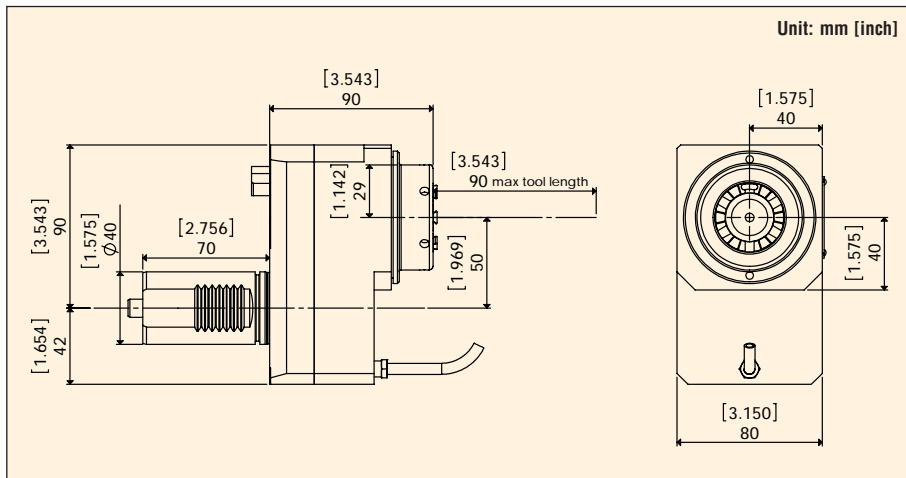

Collet Size	Clamping Range	Max. Torque Nm (ft/lbs)	Input/Output RPM (Max.)	Gear Ratio	Input/Output Rotation	Coolant	Spindle Wrench	Nut Wrench
ER32	1-20mm	50 (36.8)	6500/6500	11	CW-CCW	External	107642	112900

Please refer to pages 36 - 39 for ER Series Collets and ER Tap Collets details. Wrenches not included with holder.

## ER32 Offset Type

Part # MZMP47-ER32X-OFF-C

Mimatic Part # (l d): 05.0611.7143.505  
Mimatic Part # (e w): 124255



Clockwise Input

Counterclockwise Output

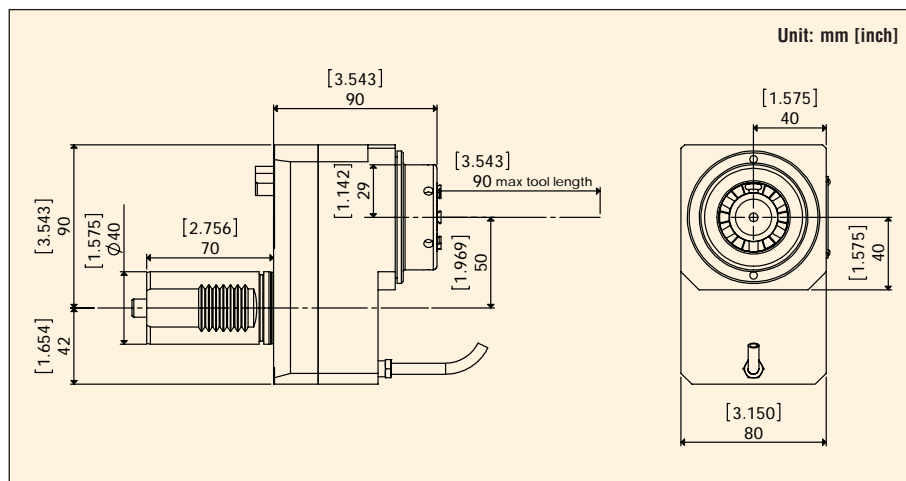

Collet Size	Clamping Range	Max. Torque Nm (ft/lbs)	Input/Output RPM (Max.)	Gear Ratio	Input/Output Rotation	Coolant	Spindle Wrench	Nut Wrench
ER32	1-20mm	50 (36.8)	6500/6500	11	CW-CCW	Internal (1000 PSI)	107642	112900

Please refer to pages 36 - 39 for ER Series Collets and ER Tap Collets details. Wrenches not included with holder. **Internal coolant tools must not be run dry.**



## ER25 Offset Type

Part # MZMP47-ER25X-OFF-HS

Mimatic Part # (l d): 05.0412.7143.404  
Mimatic Part # (e w): 124065

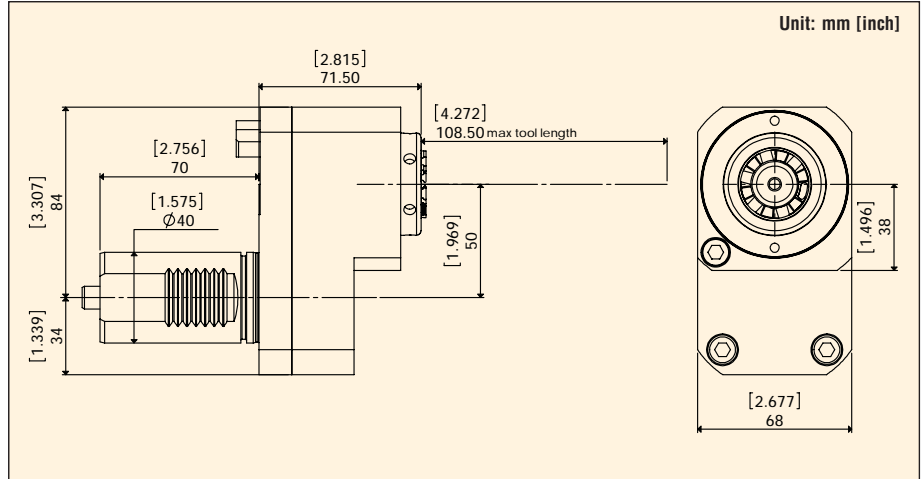

Collet Size	Clamping Range	Max. Torque Nm (ft/lbs)	Input/Output RPM (Max.)	Gear Ratio	Input/Output Rotation	Coolant	Spindle Wrench	Nut Wrench
ER25	0.5-16 mm	25 (18.4)	6500/13000	12	CW-CW	External	107446	112913

Please refer to pages 36 - 39 for ER Series Collets and ER Tap Collets details. Wrenches not included with holder.

## ER25 Offset Type

Part # MZMP47-ER25X-OFF-HSC

Mimatic Part # (l d): 05.0612.7143.404  
Mimatic Part # (e w): 124343

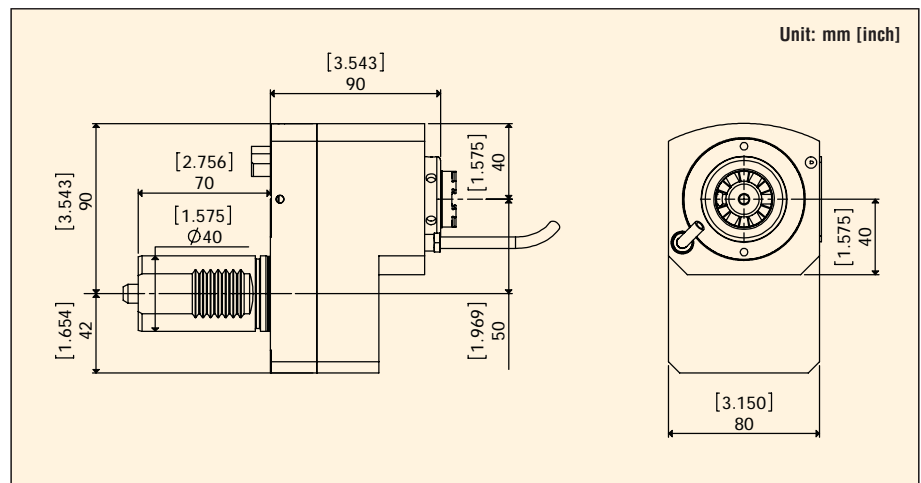
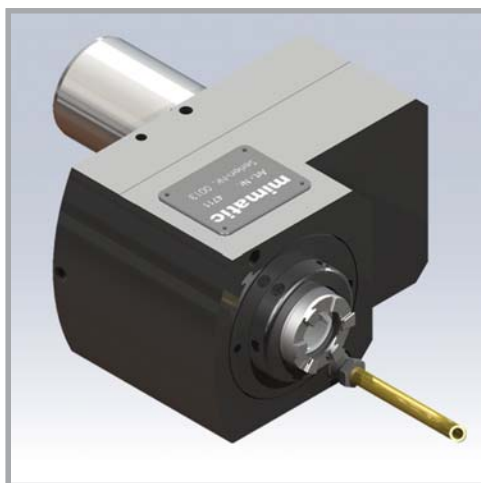
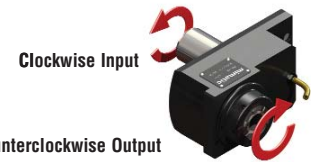

Collet Size	Clamping Range	Max. Torque Nm (ft/lbs)	Input/Output RPM (Max.)	Gear Ratio	Input/Output Rotation	Coolant	Spindle Wrench	Nut Wrench
ER25	0.5-16 mm	25 (18.4)	6500/13000	12	CW-CCW	Internal (1000 PSI)	107446	112913

Please refer to pages 36 - 39 for ER Series Collets and ER Tap Collets details. Wrenches not included with holder. **Internal coolant tools must not be run dry.**

## MI50 Offset Type

Part # MZMP47-MI50X-OFF

Mimatic Part # (l d): 05.0411.7141.MI50  
Mimatic Part # (e w): 124014

Clockwise Input

Counterclockwise Output

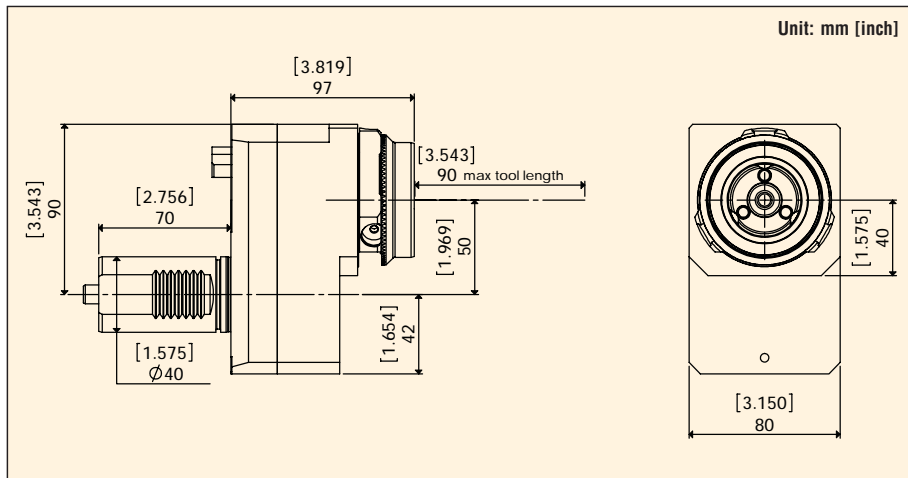
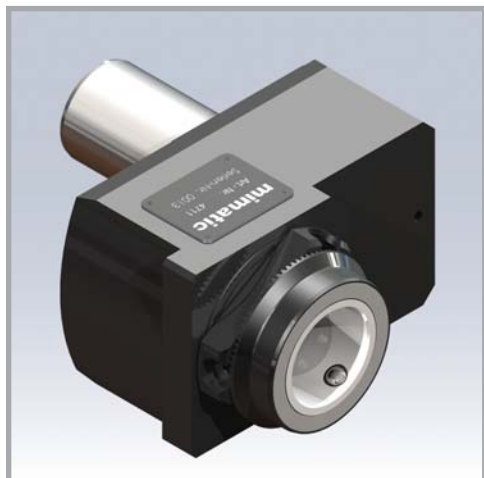

Collet Size	Clamping Range	Max. Torque Nm (ft/lbs)	Input/Output RPM (Max.)	Gear Ratio	Input/Output Rotation	Coolant	Spindle Wrench
MI50	-	50 (36.8)	6500/6500	11	CW-CCW	External	170419

Please refer to pages 40 - 44 for MI attachments details. Wrenches not included with holder.

## MI50 Offset Type

Part # MZMP47-MI50X-OFF-C

Mimatic Part # (l d): 05.0211.7141.MI50  
Mimatic Part # (e w): 123684



Clockwise Input

Counterclockwise Output

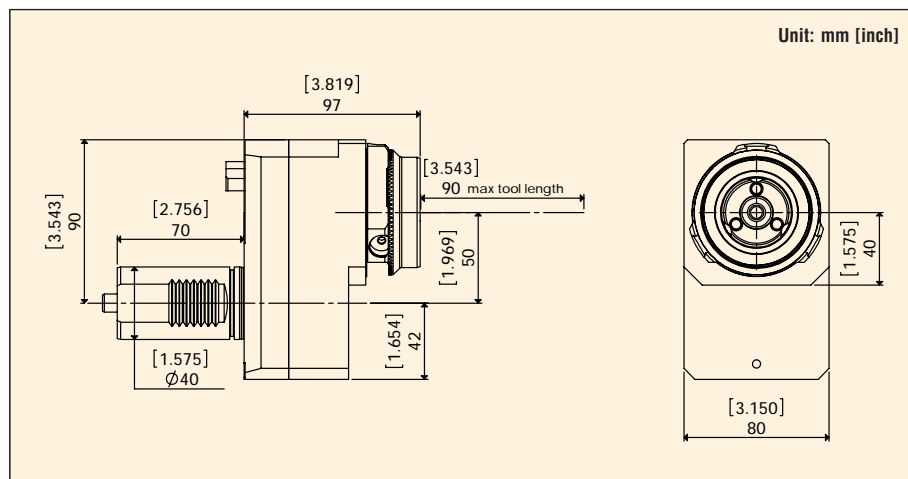
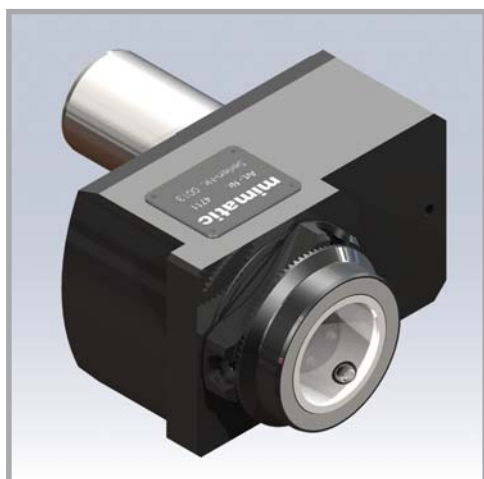

Collet Size	Clamping Range	Max. Torque Nm (ft/lbs)	Input/Output RPM (Max.)	Gear Ratio	Input/Output Rotation	Coolant	Spindle Wrench
MI50	-	50 (36.8)	6500/6500	11	CW-CCW	Internal (1000 PSI)	170419

Please refer to pages 40 - 44 for MI attachments details. Wrenches not included with holder. Internal coolant tools must not be run dry.

## ER32 90 Degree Angle

Part # MZMP47-ER32Z

Mimatic Part # (d): 05.1311.7141.505  
Mimatic Part # (e w): 124619

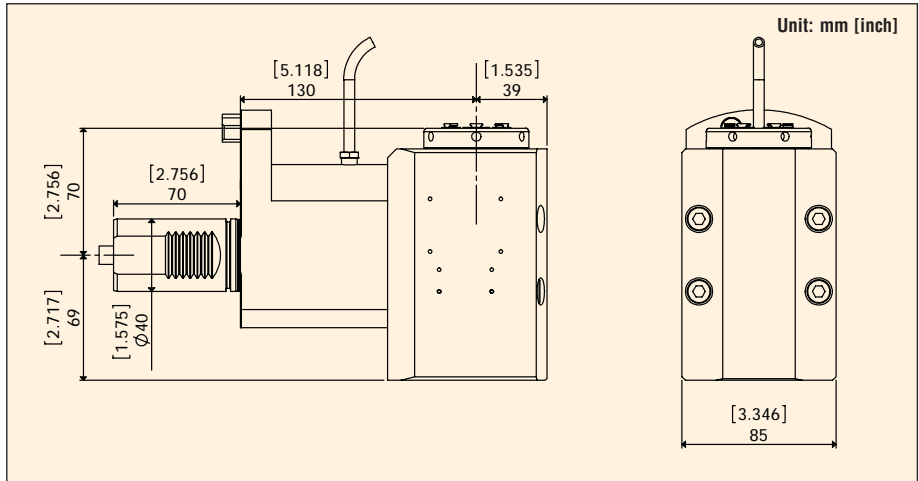
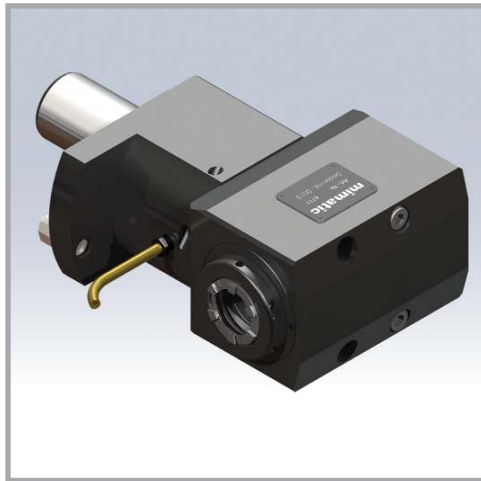
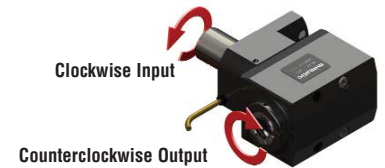

Collet Size	Clamping Range	Max. Torque Nm (ft/lbs)	Input/Output RPM (Max.)	Gear Ratio	Input/Output Rotation	Coolant	Spindle Wrench	Nut Wrench
ER32	1-20mm	50 (36.8)	6500/6500	11	CW-CCW	External	107642	112900

Please refer to pages 36 - 39 for ER Series Collets and ER Tap Collets details. Wrenches not included with holder.

## ER32 90 Degree Angle

Part # MZMP47-ER32Z-C

Mimatic Part # (d): 05.1611.7141.505  
Mimatic Part # (e w): 124864

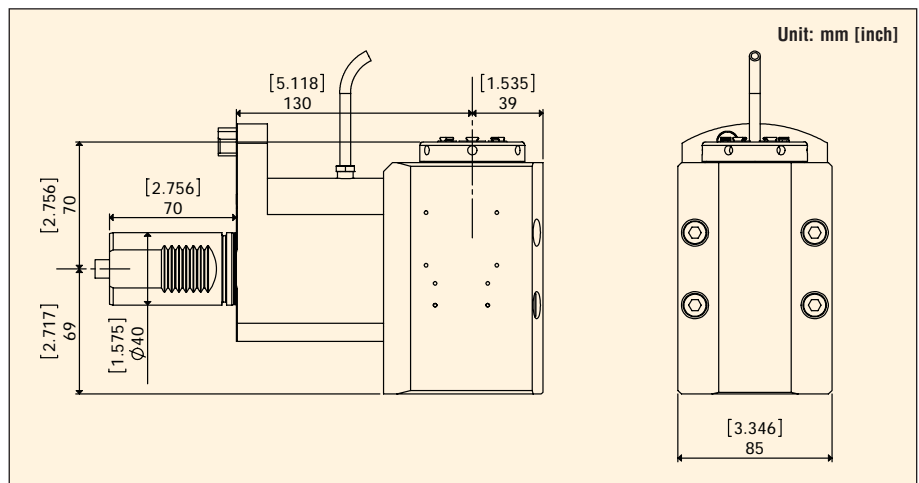
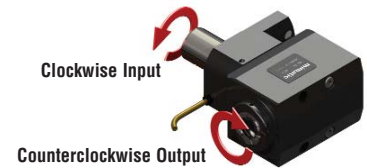

Collet Size	Clamping Range	Max. Torque Nm (ft/lbs)	Input/Output RPM (Max.)	Gear Ratio	Input/Output Rotation	Coolant	Spindle Wrench	Nut Wrench
ER32	1-20mm	50 (36.8)	6500/6500	11	CW-CCW	Internal (1000 PSI)	107642	112900

Please refer to pages 36 - 39 for ER Series Collets and ER Tap Collets details. Wrenches not included with holder. **Internal coolant tools must not be run dry.**

# ER32 90 Degree Angle

Part # MZMP47-ER32Z-HSC

Mimatic Part # (l d): 05.1612.7141.505  
Mimatic Part # (e w): 124916

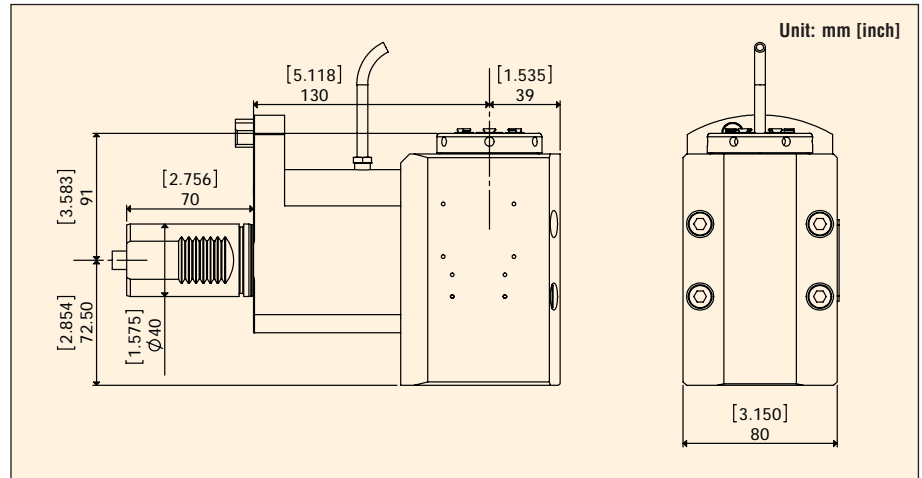
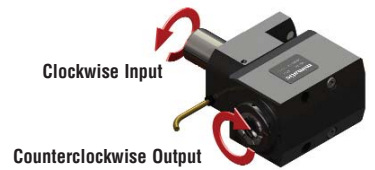

Collet Size	Clamping Range	Max. Torque Nm (ft/lbs)	Input/Output RPM (Max.)	Gear Ratio	Input/Output Rotation	Coolant	Spindle Wrench	Nut Wrench
ER32	1-20mm	25 (18.4)	6500/13000	12	CW-CCW	Internal (1000 PSI)	107642	112900

Please refer to pages 36 - 39 for ER Series Collets and ER Tap Collets details. Wrenches not included with holder. **Internal coolant tools must not be run dry.**

# ER25 90 Degree Angle

Part # MZMP47-ER25Z-HS

Mimatic Part # (l d): 05.1312.7141.504  
Mimatic Part # (e w): 124690

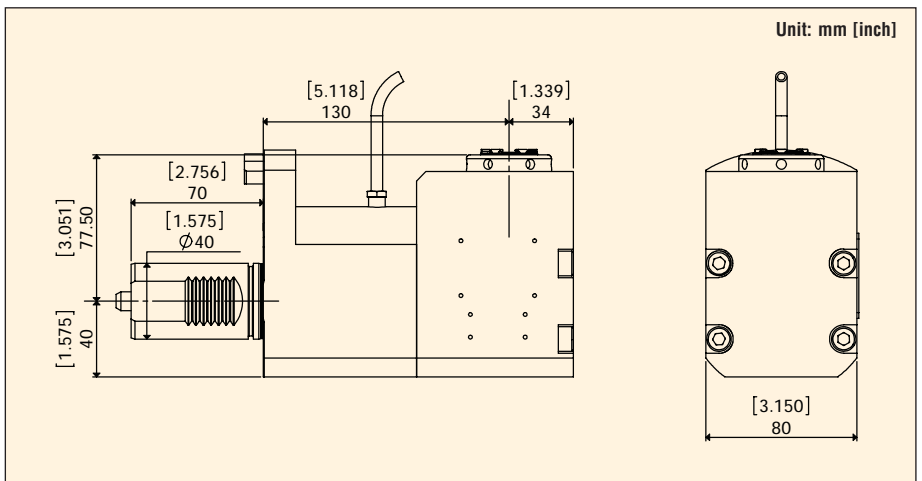
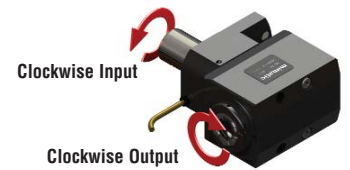

Collet Size	Clamping Range	Max. Torque Nm (ft/lbs)	Input/Output RPM (Max.)	Gear Ratio	Input/Output Rotation	Coolant	Spindle Wrench	Nut Wrench
ER25	0.5-16mm	25 (18.4)	6500/13000	12	CW-CW	External	107446	112913

Please refer to pages 36 - 39 for ER Series Collets and ER Tap Collets details. Wrenches not included with holder.

## MI50 90 Degree Angle

Part # MZMP47-MI50Z

Mimatic Part # (old): 05.1311.7141.MI50  
Mimatic Part # (new): 124623

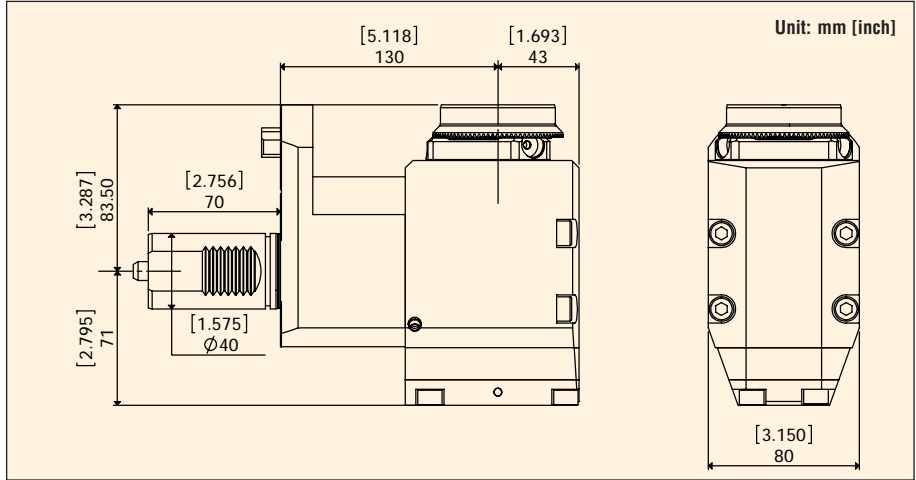
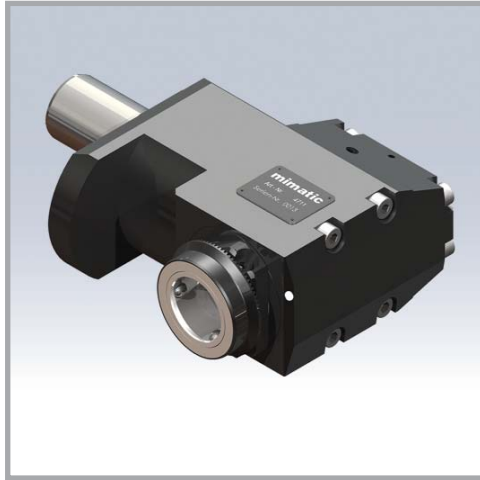
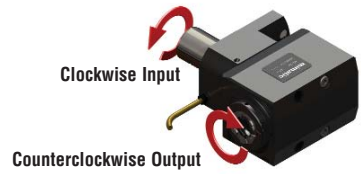

Collet Size	Clamping Range	Max. Torque Nm (ft/lbs)	Input/Output RPM (Max.)	Gear Ratio	Input/Output Rotation	Coolant	Spindle Wrench	Nut Wrench
MI50	-	50 (36.8)	6500/6500	11	CW-CCW	External	170419	Various

Please refer to pages 40 - 44 for MI attachments details. Wrenches not included with holder.

## MI50 90 Degree Angle

Part # MZMP47-MI50Z-C

Mimatic Part # (old): 05.1611.7141.MI50  
Mimatic Part # (new): 124866

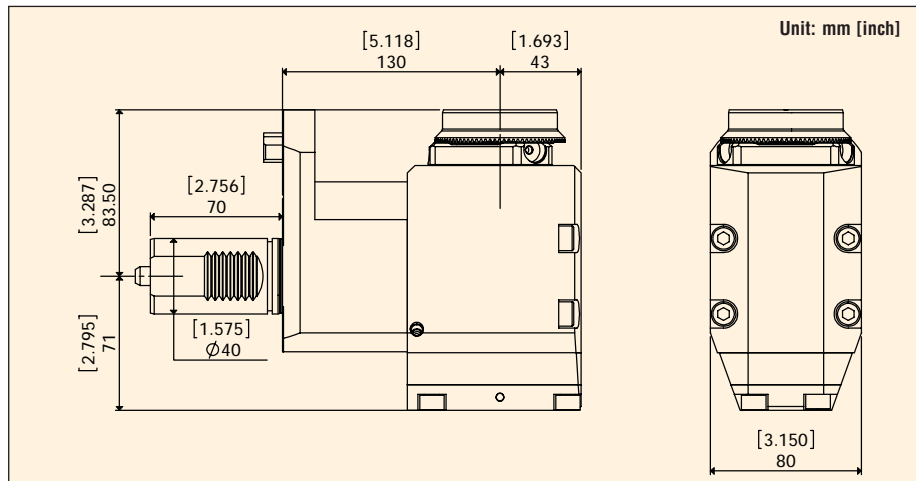
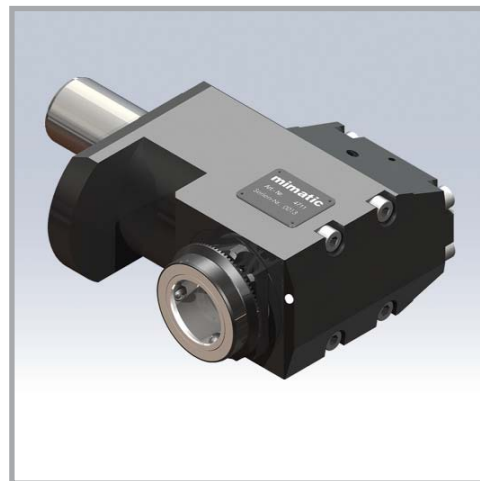
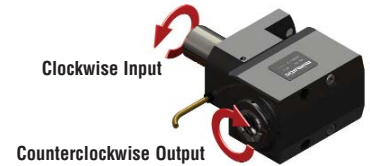

Collet Size	Clamping Range	Max. Torque Nm (ft/lbs)	Input/Output RPM (Max.)	Gear Ratio	Input/Output Rotation	Coolant	Spindle Wrench
MI50	-	50 (36.8)	6500/6500	11	CW-CCW	Internal (1000 PSI)	170419

Please refer to pages 40 - 44 for MI attachments details. Wrenches not included with holder. **Internal coolant tools must not be run dry.**



# ER16 Angle-Unit Adjustable

Part # MZMP47-ER16-AD

Mimatic Part # (old): 05.1911.7141.402  
Mimatic Part # (new): 125025

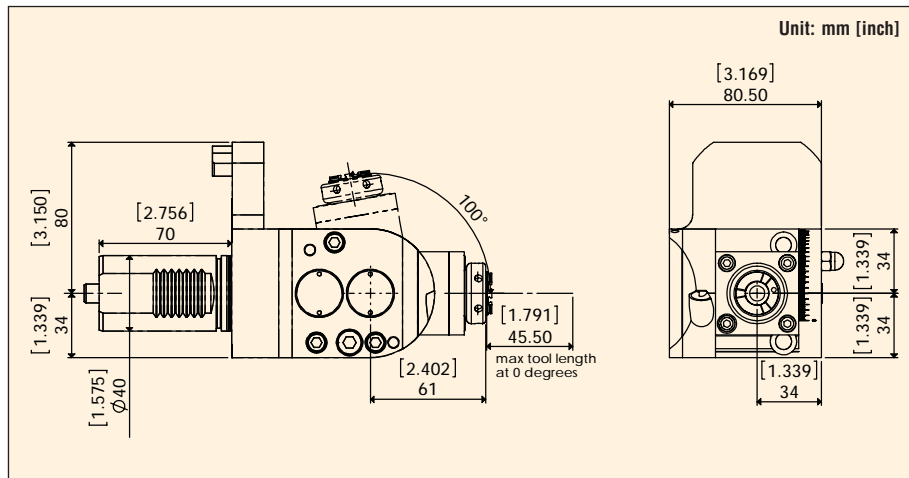
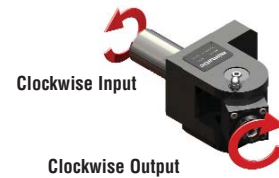

Collet Size	Clamping Range	Max. Torque Nm (ft/lbs)	Input/Output RPM (Max.)	Gear Ratio	Input/Output Rotation	Coolant	Spindle Wrench	Nut Wrench
ER16	0.5-10mm	6 (4.4)	6500/6500	11	CW-CW	External	107557	112954

Please refer to pages 36 - 39 for ER Series Collets and ER Tap Collets details. Wrenches not included with holder.

# ER16 Angle-Unit Adjustable

Part # MZMP47-ER16-AD-HS

Mimatic Part # (old): 05.1914.7141.402  
Mimatic Part # (new): 125053

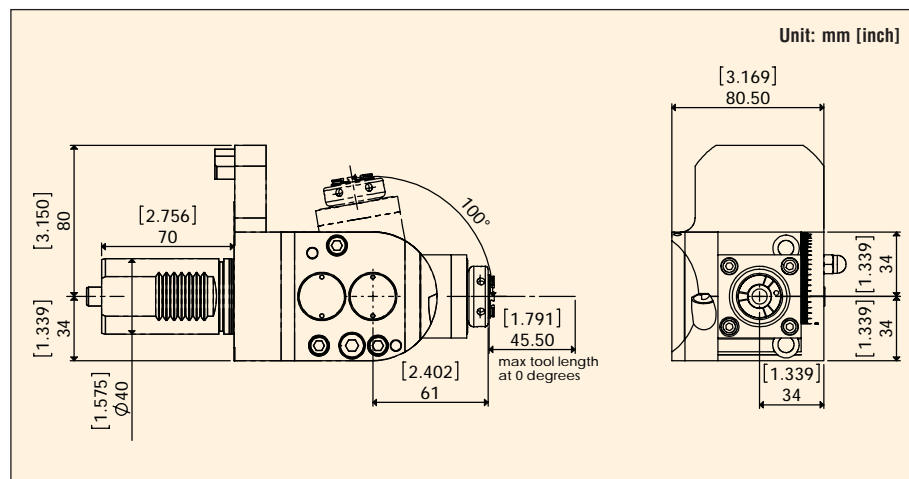
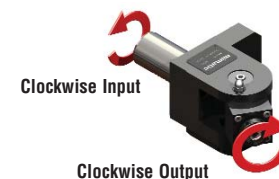

Collet Size	Clamping Range	Max. Torque Nm (ft/lbs)	Input/Output RPM (Max.)	Gear Ratio	Input/Output Rotation	Coolant	Spindle Wrench	Nut Wrench
ER16	0.5-10mm	6 (4.4)	3750/15000	14	CW-CW	External	107557	112954

Please refer to pages 36 - 39 for ER Series Collets and ER Tap Collets details. Wrenches not included with holder.

## ER25 Y-Unit Adjustable

Part # MZMP47-ER25Y-AD

Mimatic Part # (l d): 05.0511.7143.404  
Mimatic Part # (e w): 124116

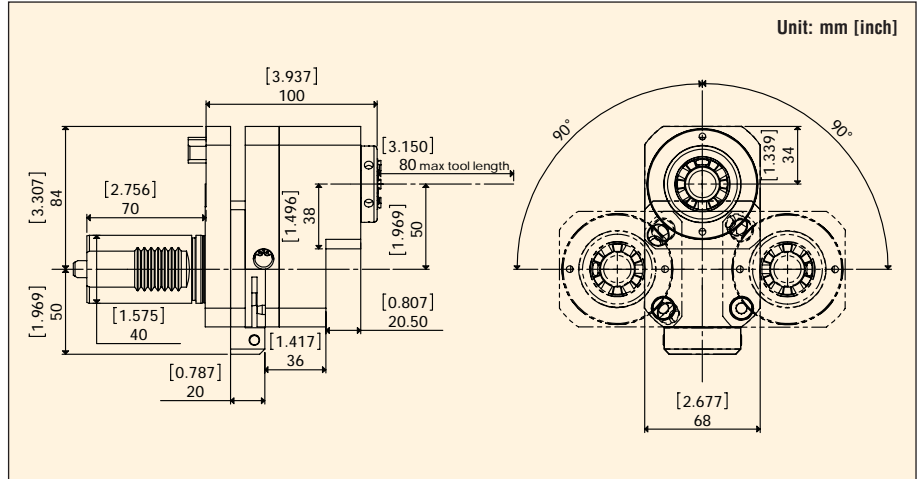
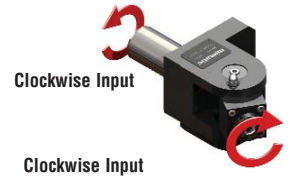

Collet Size	Clamping Range	Max. Torque Nm (ft/lbs)	Input/Output RPM (Max.)	Gear Ratio	Input/Output Rotation	Coolant	Spindle Wrench	Nut Wrench
ER25	0.5-16mm	25 (18.4)	6500/6500	11	CW-CCW	External	107446	112913

Please refer to pages 36 - 39 for ER Series Collets and ER Tap Collets details. +/- 50mm Y-axis adjustment. Wrenches not included with holder.

## Saw Blade Holder - 16mm

Part # MZMP47-SB22X

Mimatic Part # (l d): 05.35131.7141  
Mimatic Part # (e w): 125103

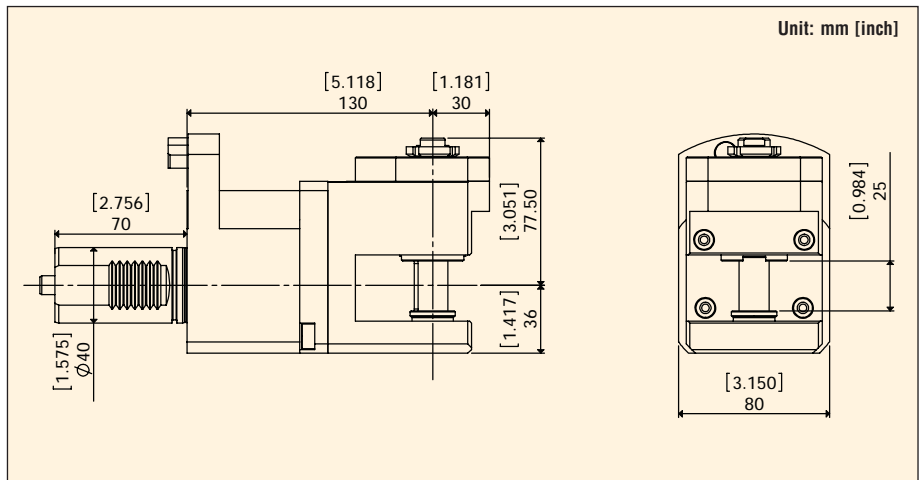
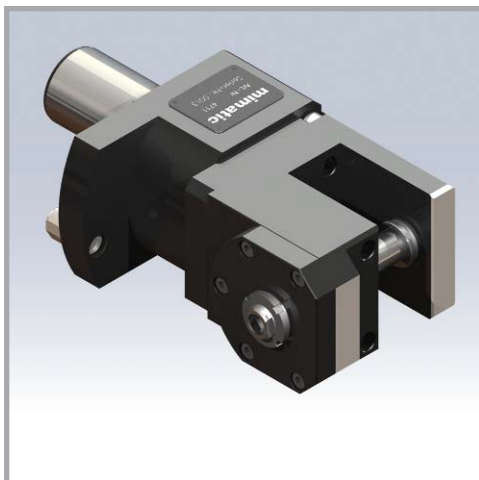
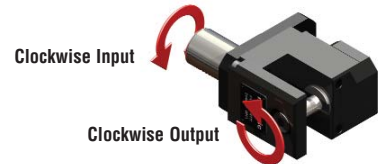

Collet Size	Clamping Range	Max. Torque Nm (ft/lbs)	Input/Output RPM (Max.)	Gear Ratio	Input/Output Rotation	Coolant	Spindle Wrench	Nut Wrench
16mm arbor	-	20 (14.7)	6500/2450	2.661	CW-CW	External	-	-

Inch size arbor available.

# Saw Blade Holder - 16mm

Part # MZMP47-SB22X-HT

Mimatic Part # (l d): 05.36131.7141.22  
Mimatic Part # (e w): 101820

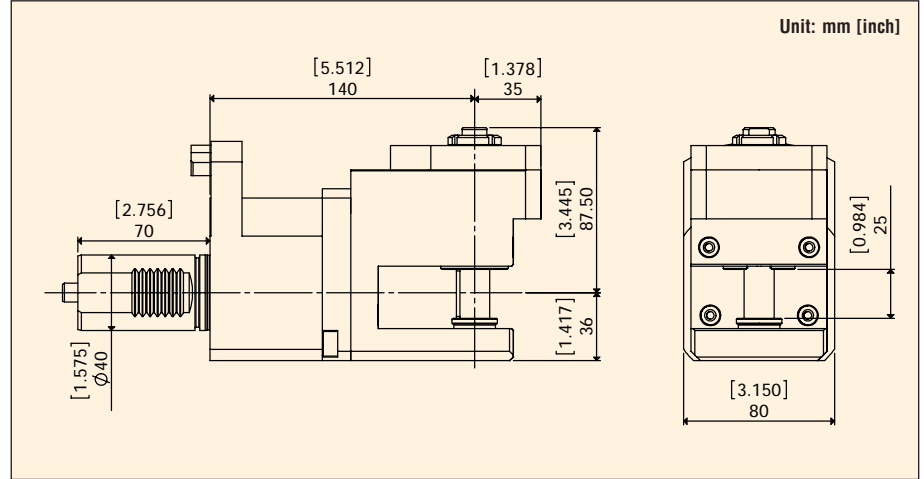
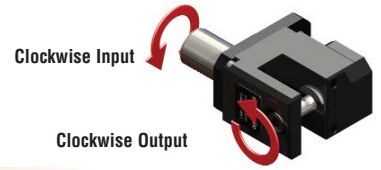

Collet Size	Clamping Range	Max. Torque Nm (ft/lbs)	Input/Output RPM (Max.)	Gear Ratio	Input/Output Rotation	Coolant	Spindle Wrench	Nut Wrench
16mm arbor	-	40 (29.5)	6500/2450	2.661	CW-CW	External	-	-

Inch size arbor available.



# Combination Holder

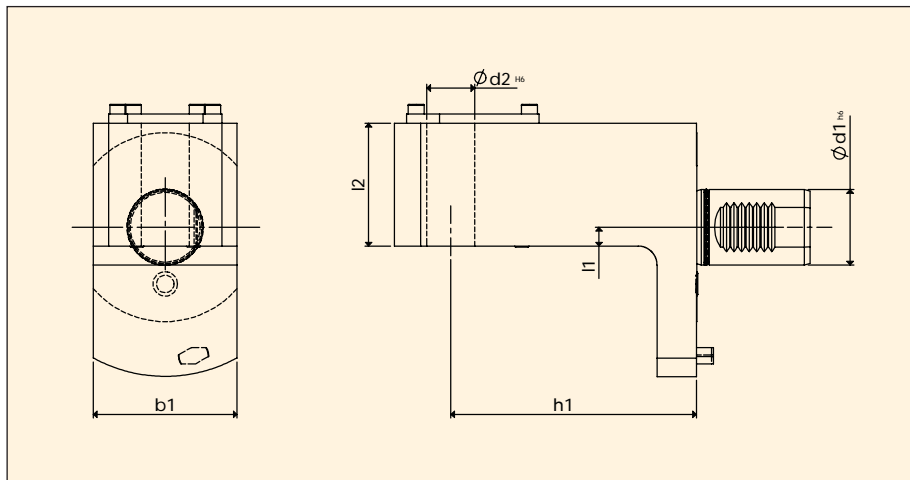

Lyndex-Nikken Part Number	Mimatic Part# (new)	Size	d1	d2	l1	l2	b1	h1
MZMP47-BG10Z-C	174947	VDI 40	1.575	1.000	0.394	2.756	2.992	5.906
MZMP47-BG12Z-C	174946	VDI 40	1.575	1.250	0.394	2.756	2.992	5.906
MZMP47-BG15Z-C	117965	VDI 40	1.575	1.500	0.394	2.756	2.992	5.906
MZMP47-BG20Z-C	-	VDI 40		2.000	0.394	2.756	2.992	5.906

Metric sizes available. Tool can be used for coolant kub drills.

# OD Turning Tool

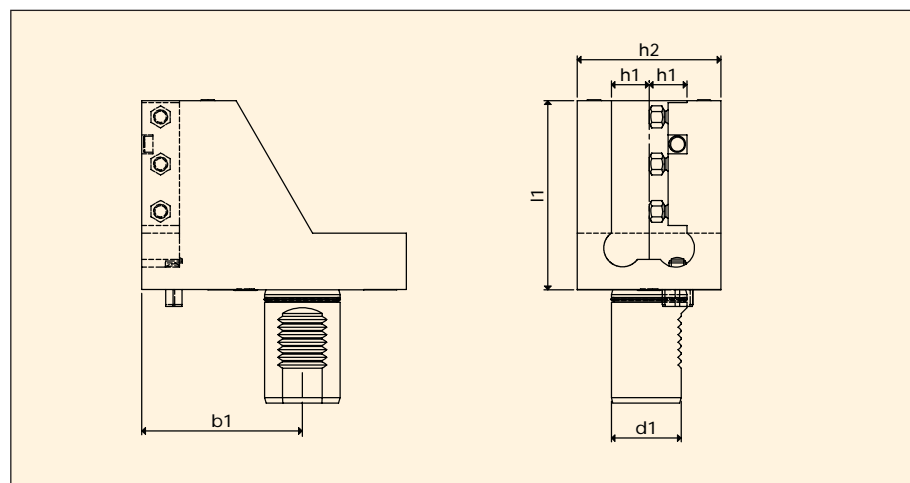
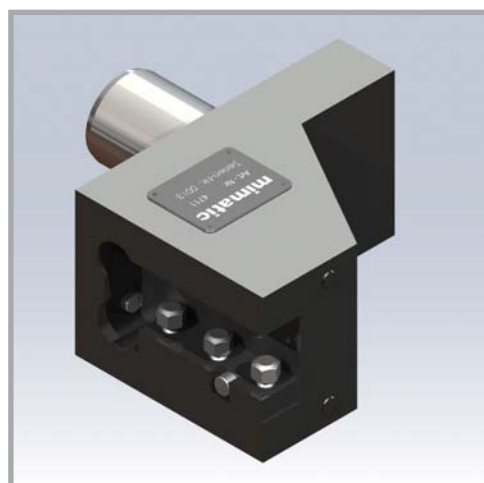

Lyndex-Nikken Part Number	Mimatic Part# (new)	Size	d1	l1	h2	b1	h1
MZMP47-OD10X	117999	VDI 40	1.575	4.724	1.969	3.268	1.000

Right hand and left hand reversible.

MP 620/6200 & HQR-200

# Face Turning

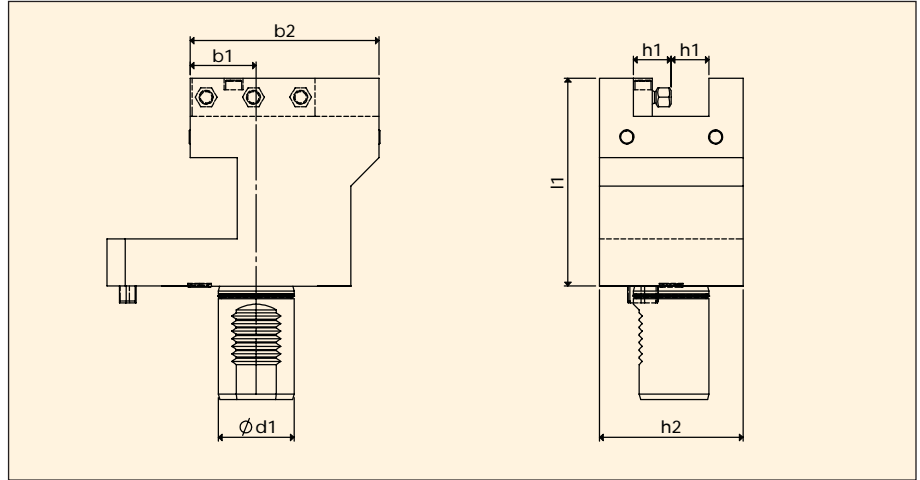

Lyndex-Nikken Part Number	Mimatic Part# (new)	Size	d1	b2	l1	h2	b1	h1
MZMP47-ID10Z	169069	VDI 40	1.575	4.528	5.630	3.150	1.378	1.000

Right hand and left hand reversible.



## ER40 Offset Type

Part # MZMP5-ER40X-OFF-C

Mimatic Part # (l d): 06.0611.7151.606  
Mimatic Part # (e w): 131556

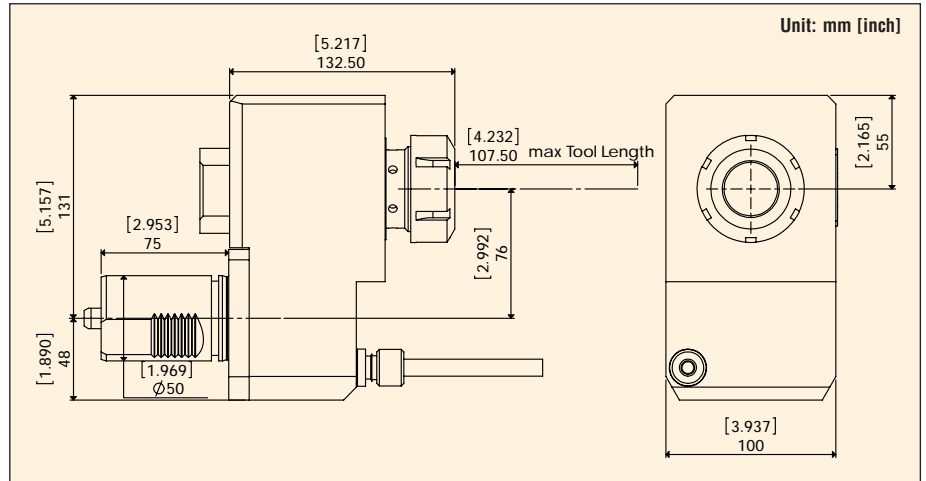
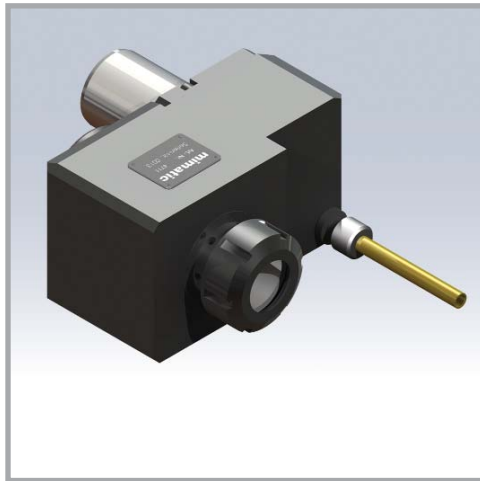
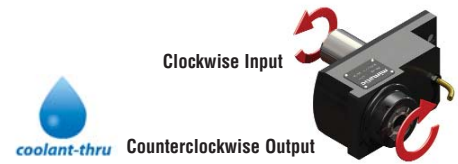

Collet Size	Clamping Range	Max. Torque Nm (ft/lbs)	Input/Output RPM (Max.)	Gear Ratio	Input/Output Rotation	Coolant	Spindle Wrench	Nut Wrench
ER40	2.0-26 mm	100 (73.71)	6500/6500	11	CW-CCW	Internal	107446	107628

Please refer to pages 36 - 39 for ER Series Collets and ER Tap Collets details. Wrenches not included with holder. **Internal coolant tools must not be run dry.**

## MI63 Offset Type

Part # MZMP5-MI63X-OFF-C

Mimatic Part # (l d): 05.0211.7150.MI63  
Mimatic Part # (e w): 100245

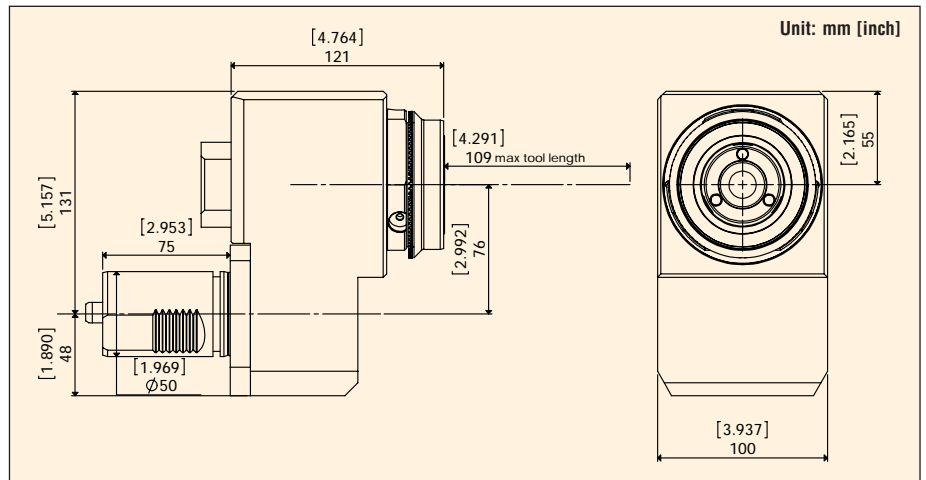
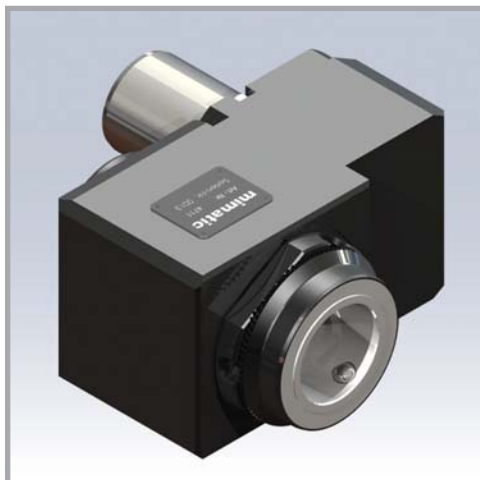
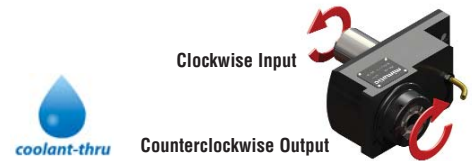

Collet Size	Clamping Range	Max. Torque Nm (ft/lbs)	Input/Output RPM (Max.)	Gear Ratio	Input/Output Rotation	Coolant	Spindle Wrench	Nut Wrench
MI63	-	100 (73.71)	6500/6500	11	CW-CCW	Internal	170419	Various

Please refer to pages 40 - 44 for MI attachments details. Wrenches not included with holder. **Internal coolant tools must not be run dry.**

## CT40 Offset Type

Part # MZMP5-CT40

Mimatic Part # (n e w): 131522



Clockwise Input

Counterclockwise Output

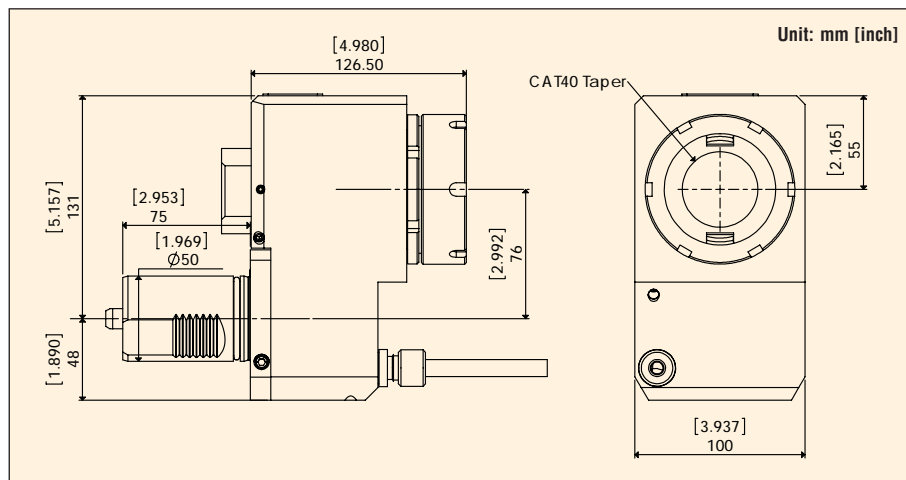
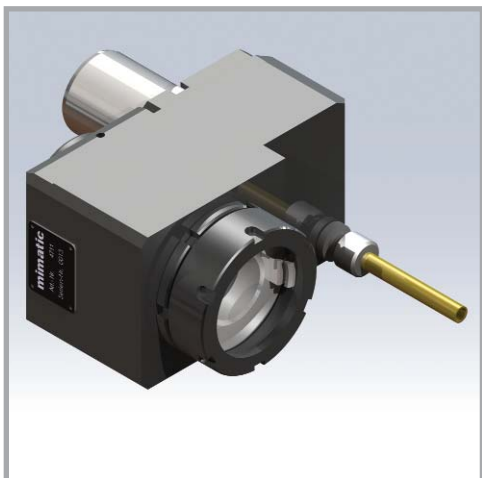

Collet Size	Clamping Range	Max. Torque Nm (ft/lbs)	Input/Output RPM (Max.)	Gear Ratio	Input/Output Rotation	Coolant	Spindle Wrench	Nut Wrench
CAT40	-	100 (73.71)	6500/6500	11	CW-CCW	Internal (1000 PSI)	170566	170566

Wrenches not included with holder. **Internal coolant tools must not be run dry.**

## ER40 90 Degree Angle

Part # MZMP5-ER40Z-C

Mimatic Part # (ol d): 06.1611.7150.606  
Mimatic Part # (n e w): 131597



Clockwise Input

Counterclockwise Output

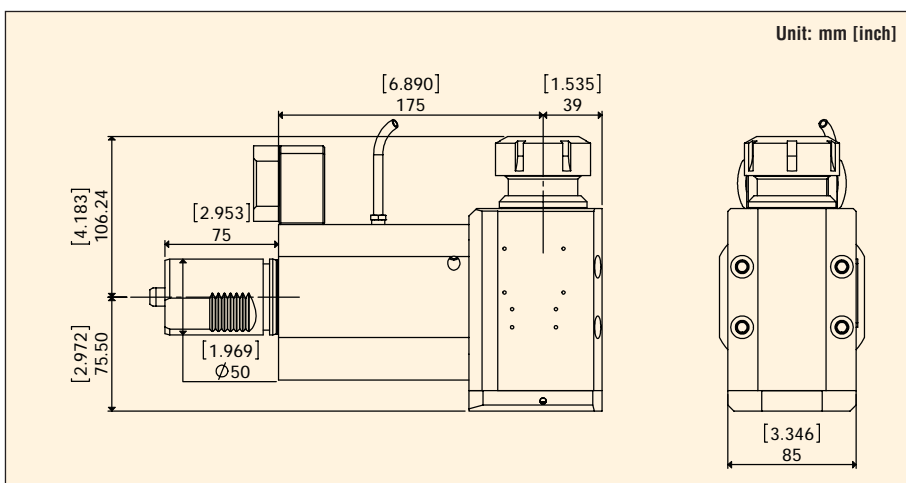

Collet Size	Clamping Range	Max. Torque Nm (ft/lbs)	Input/Output RPM (Max.)	Gear Ratio	Input/Output Rotation	Coolant	Spindle Wrench	Nut Wrench
ER40	2.0-26 mm	100 (73.71)	6500/6500	11	CW-CCW	Internal (1000 PSI)	170446	107628

Please refer to pages 36 - 39 for ER Series Collets and ER Tap Collets details. Wrenches not included with holder. **Internal coolant tools must not be run dry.**

## MI63 90 Degree Angle

Part # MZMP5-MI63Z-C

Mimatic Part # (l d): 05.1611.7150.MI63  
Mimatic Part # (e w): 101513

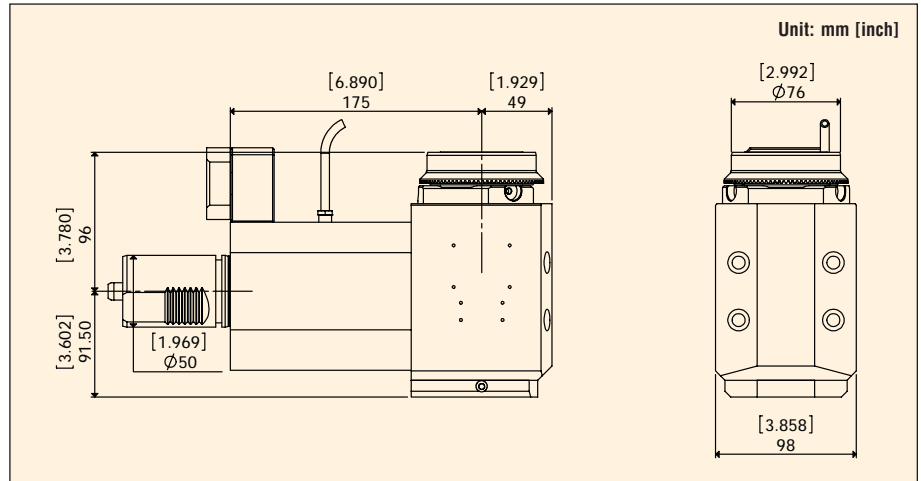
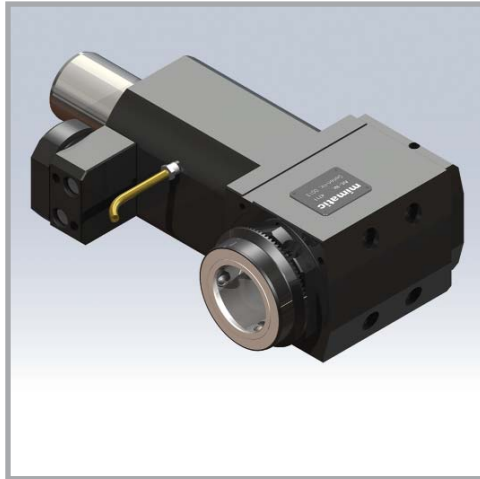
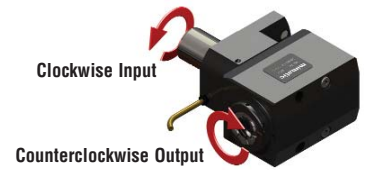

Collet Size	Clamping Range	Max. Torque Nm (ft/lbs)	Input/Output RPM (Max.)	Gear Ratio	Input/Output Rotation	Coolant	Spindle Wrench	Nut Wrench
MI63	-	100 (73.71)	6500/6500	11	CW-CCW	Internal (1000 PSI)	170419	Various

Please refer to pages 40 - 44 for MI attachments details. Wrenches not included with holder. **Internal coolant tools must not be run dry.**

## CAT40 90 Degree Angle

Part # MZMP5-CT40Z

Mimatic Part # (e w): 131580

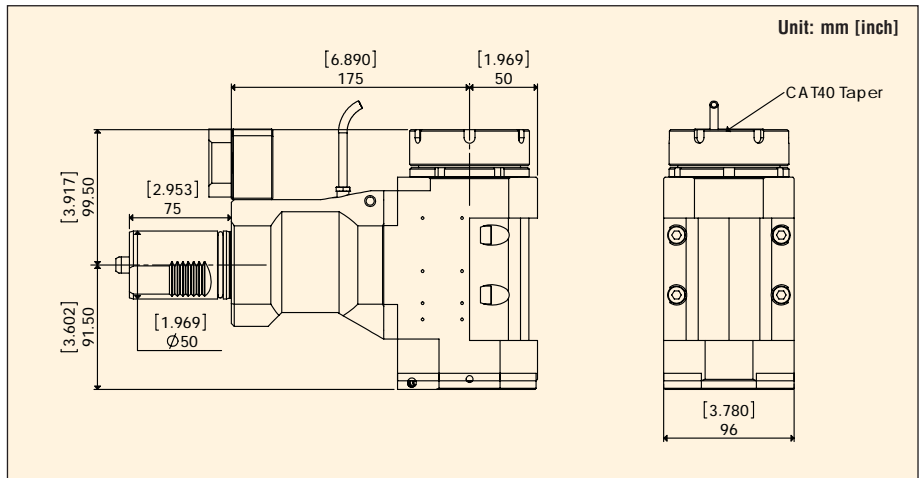
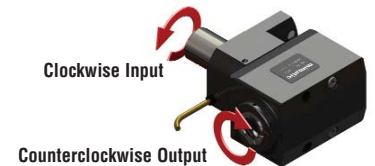

Collet Size	Clamping Range	Max. Torque Nm (ft/lbs)	Input/Output RPM (Max.)	Gear Ratio	Input/Output Rotation	Coolant	Spindle Wrench	Nut Wrench
CAT40	-	100 (73.71)	6500/6500	11	CW-CCW	Internal (1000 PSI)	170566	170566

Wrenches not included with holder. **Internal coolant tools must not be run dry.**

# Combination Holder

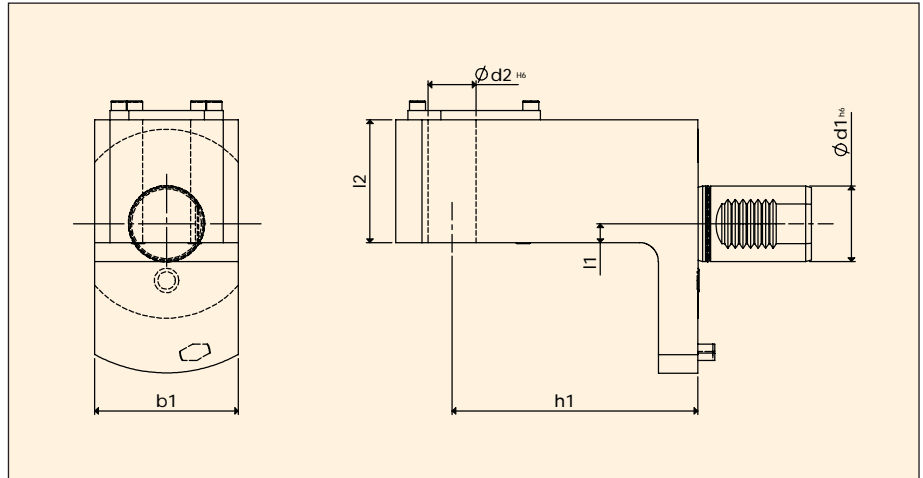

Lyndex-Nikken Part Number	Mimatic Part# (new)	Size	d1	d2	l1	l2	b1	h1
MZMP5-BG20Z-C	174951	VDI 50	1.969	2.000	1.378	3.937	3.937	7.480

Metric sizes available. Tool can be used for coolant kub drills.

# OD Turning Tool

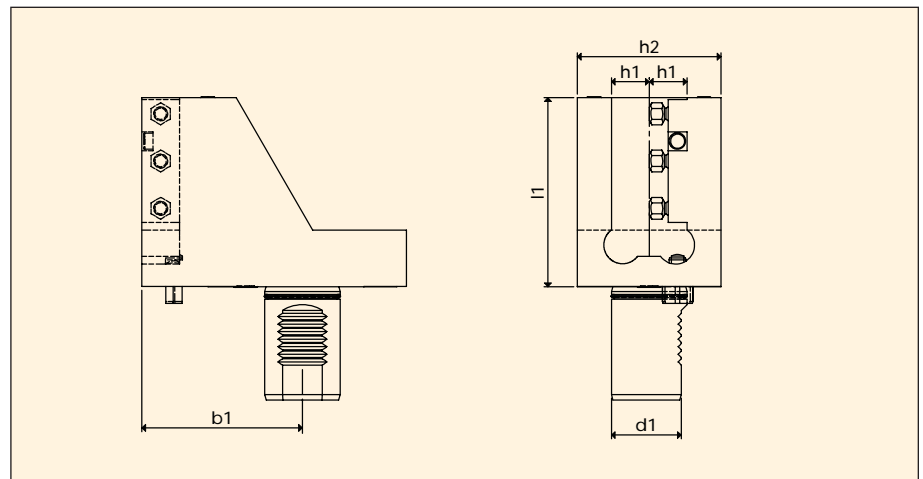

Lyndex-Nikken Part Number	Mimatic Part# (new)	Size	d1	l1	h2	b1	h1
MZMP5-OD10X	174959	VDI 50	1.969	5.906	3.937	4.646	1.000

Right hand and left hand reversible.

# Face Turning

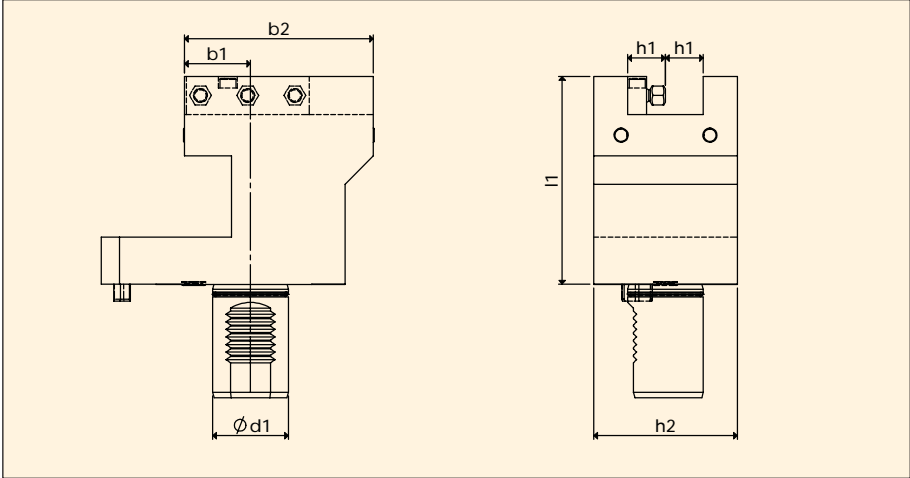

Lyndex-Nikken Part Number	Mimatic Part# (new)	Size	d1(in)	b2(in)	l1(in)	h2(in)	b1(in)	h1(mm)
MZMP5-1D10Z	174957	VDI 50	1.969	3.858	6.614	3.937	1.929	1.000

Right hand and left hand reversible.



# B Series Collets

## STANDARD (INCH)

SIZE	ER16	ER20	ER25	ER32	ER40
1/32"	E16-002	-	-	-	-
1/16"	E16-004	E20-004	E25-004	-	-
3/32"	E16-006	E20-006	E25-006	-	-
1/8"	E16-008	E20-008	E25-008	E32-008	-
5/32"	E16-010	E20-010	E25-010	E32-010	E40-010
3/16"	E16-012	E20-012	E25-012	E32-012	E40-012
7/32"	E16-014	E20-014	E25-014	E32-014	E40-014
1/4"	E20-016	E20-016	E25-016	E32-016	E40-016
9/32"	E20-018	E20-018	E25-018	E32-018	E40-018
5/16"	E20-020	E20-020	E25-020	E32-020	E40-020
11/32"	E20-022	E20-022	E25-022	E32-022	E40-022
3/8"	E20-024	E20-024	E25-024	E32-024	E40-024
13/32"	E20-026	E20-026	E25-026	E32-026	E40-026
7/16"	-	E20-028	E25-028	E32-028	E40-028
15/32"	-	E20-030	E25-030	E32-030	E40-030
1/2"	-	E20-032	E25-032	E32-032	E40-032
17/32"	-	-	E25-034	E32-034	E40-034
9/16"	-	-	E25-036	E32-036	E40-036
19/32"	-	-	E25-038	E32-038	E40-038
5/8"	-	-	E25-040	E32-040	E40-040
21/32"	-	-	-	E32-042	E40-042
11/16"	-	-	-	E32-044	E40-044
23/32"	-	-	-	E32-046	E40-046
3/4"	-	-	-	E32-048	E40-048
25/32"	-	-	-	E32-050	E40-050
13/16"	-	-	-	-	E40-052
27/32"	-	-	-	-	E40-044
7/8"	-	-	-	-	E40-056
29/32"	-	-	-	-	E40-058
15/16"	-	-	-	-	E40-060
31/32"	-	-	-	-	E40-062
1"	-	-	-	-	E40-064

## STANDARD (METRIC)

SIZE	ER16	ER20	ER25	ER32	ER40
1.0mm	E16-039	-	-	-	-
1.5mm	E16-059	-	-	-	-
2.0mm	E16-078	E20-078	E25-078	-	-
3.0mm	E16-118	E20-118	E25-118	E32-118	-
3.5mm	E16-137	E20-137	E25-137	E32-137	-
4.0mm	E16-157	E20-157	E25-157	E32-157	E40-157
5.0mm	E16-196	E20-196	E25-196	E32-196	E40-196
6.0mm	E16-236	E20-236	E25-236	E32-236	E40-236
7.0mm	E16-275	E20-275	E25-275	E32-275	E40-275
8.0mm	E16-314	E20-314	E25-314	E32-314	E40-314
9.0mm	E16-354	E20-354	E25-354	E32-354	E40-354
10.0mm	E16-393	E20-393	E25-393	E32-393	E40-393
11.0mm	-	E20-433	E25-433	E32-433	E40-433
11.5mm	-	E20-452	E25-452	E32-452	E40-452
12.0mm	-	E20-472	E25-472	E32-472	E40-472
13.0mm	-	E20-511	E25-511	E32-511	E40-511
14.0mm	-	-	E25-551	E32-551	E40-551
15.0mm	-	-	E25-590	E32-590	E40-590
16.0mm	-	-	E25-629	E32-629	E40-629
17.0mm	-	-	-	E32-669	E40-669
18.0mm	-	-	-	E32-708	E40-708
19.0mm	-	-	-	E32-748	E40-748
19.5mm	-	-	-	E32-767	E40-767
20.0mm	-	-	-	E32-787	E40-787
21.0mm	-	-	-	-	E40-826
22.0mm	-	-	-	-	E40-866
23.0mm	-	-	-	-	E40-905
24.0mm	-	-	-	-	E40-944
25.0mm	-	-	-	-	E40-984
26.0mm	-	-	-	-	E40-1023

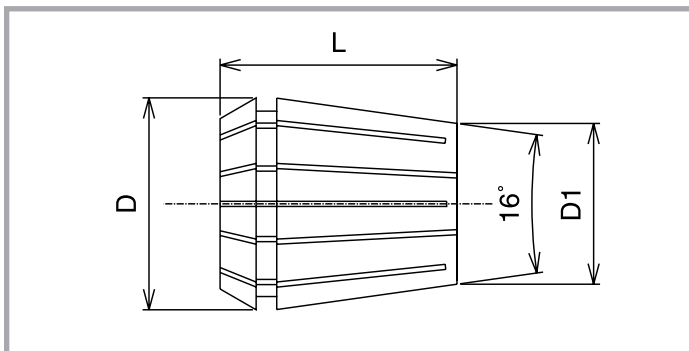

ER Standard type collet

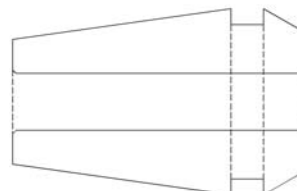

ER Counter-Bored type collet

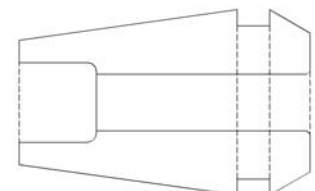

Style	D	D1	L	Collet Range	Coolant Collet Size Range	Nut Tightening Torque	
						standard collet	counter-bored collet
ER16	17.2mm	11.3mm	27.0mm	0.5 - 10.0mm	4.0 - 10.0mm (3/16" - 17/64")	30 - 37 ft-lbs	18 - 22 ft-lbs
ER20	21.2mm	14.5mm	31.0mm	1.0 - 13.0mm	5.0 - 13.0mm (5/32" - 1/2")	60 - 74 ft-lbs	42 - 52 ft-lbs
ER25	26.2mm	18.5mm	35.0mm	1.0 - 16.0mm	6.0 - 16.0mm (7/32" - 5/8")	77 - 96 ft-lbs	54 - 67 ft-lbs
ER32	33.2mm	24.4mm	40.0mm	2.0 - 20.0mm	10.0 - 20.0mm (1/4" - 25/32")	100 - 125 ft-lbs	77 - 96 ft-lbs
ER40	41.2mm	31.2mm	46.0mm	3.0mm - 26.0mm	10.0 - 26.0mm	125 - 157 ft-lbs	130 - 162 ft-lbs

# B Series Coolant Collets

## COOLANT (INCH)

SIZE	ER16	ER20	ER25	ER32
3/32"	E16-006(C)	-	-	-
7/64"	E16-007(C)	-	-	-
1/8"	E16-008(C)	-	-	-
9/64"	E16-009(C)	-	-	-
5/32"	E16-010(C)	E20-010(C)	-	-
11/64"	E16-011(C)	E20-011(C)	-	-
3/16"	E16-012(C)	E20-012(C)	-	-
13/64"	E16-013(C)	E20-013(C)	-	-
7/32"	E16-014(C)	E20-014(C)	E25-014(C)	-
15/64"	E16-015(C)	E20-015(C)	E25-015(C)	-
1/4"	E16-016(C)	E20-016(C)	E25-016(C)	E32-016(C)
17/64"	E16-017(C)	E20-017(C)	E25-017(C)	E32-017(C)
9/32"	E16-018(C)	E20-018(C)	E25-018(C)	E32-018(C)
19/64"	E16-019(C)	E20-019(C)	E25-019(C)	E32-019(C)
5/16"	E16-020(C)	E20-020(C)	E25-020(C)	E32-020(C)
21/64"	E16-021(C)	E20-021(C)	E25-021(C)	E32-021(C)
11/32"	E16-022(C)	E20-022(C)	E25-022(C)	E32-022(C)
23/64"	E16-023(C)	E20-023(C)	E25-023(C)	E32-023(C)
3/8"	E16-024(C)	E20-024(C)	E25-024(C)	E32-024(C)
25/64"	E16-025(C)	E20-025(C)	E25-025(C)	E32-025(C)
13/32"	E16-026(C)	E20-026(C)	E25-026(C)	E32-026(C)
27/64"	-	E20-027(C)	E25-027(C)	E32-027(C)
7/16"	-	E20-028(C)	E25-028(C)	E32-028(C)
29/64"	-	E20-029(C)	E25-029(C)	E32-029(C)
15/32"	-	E20-030(C)	E25-030(C)	E32-030(C)
31/64"	-	E20-031(C)	E25-031(C)	E32-031(C)
1/2"	-	E20-032(C)	E25-032(C)	E32-032(C)
33/64"	-	-	E25-033(C)	E32-033(C)
17/32"	-	-	E25-034(C)	E32-034(C)
35/64"	-	-	E25-035(C)	E32-035(C)
9/16"	-	-	E25-036(C)	E32-036(C)
37/64"	-	-	E25-037(C)	E32-037(C)
19/32"	-	-	E25-038(C)	E32-038(C)
39/64"	-	-	E25-039(C)	E32-039(C)
5/8"	-	-	E25-040(C)	E32-040(C)
41/64"	-	-	-	E32-041(C)
21/32"	-	-	-	E32-042(C)
43/64"	-	-	-	E32-043(C)
11/16"	-	-	-	E32-044(C)
45/64"	-	-	-	E32-045(C)
23/32"	-	-	-	E32-046(C)
47/64"	-	-	-	E32-047(C)
3/4"	-	-	-	E32-048(C)
49/64"	-	-	-	E32-049(C)
25/32"	-	-	-	E32-050(C)

## COOLANT (METRIC)

SIZE	ER16	ER20	ER25	ER32	ER40
4.0mm	E16-157(C)	-	-	-	-
4.5mm	E16-177(C)	-	-	-	-
5.0mm	E16-196(C)	E20-196(C)	-	-	-
5.5mm	E16-216(C)	E20-216(C)	-	-	-
6.0mm	E16-236(C)	E20-236(C)	E25-236(C)	-	-
6.5mm	E16-255(C)	E20-255(C)	E25-255(C)	-	-
7.0mm	E16-275(C)	E20-275(C)	E25-275(C)	-	-
7.5mm	E16-295(C)	E20-295(C)	E25-295(C)	-	-
8.0mm	E16-314(C)	E20-314(C)	E25-314(C)	-	-
8.5mm	E16-334(C)	E20-334(C)	E25-334(C)	-	-
9.0mm	E16-354(C)	E20-354(C)	E25-354(C)	-	-
9.5mm	E16-374(C)	E20-374(C)	E25-374(C)	-	-
10.0mm	E16-393(C)	E20-393(C)	E25-393(C)	E32-393(C)	E40-393(C)
10.5mm	-	E20-413(C)	E25-413(C)	E32-413(C)	E40-413(C)
11.0mm	-	E20-433(C)	E25-433(C)	E32-433(C)	E40-433(C)
11.5mm	-	E20-452(C)	E25-452(C)	E32-452(C)	E40-452(C)
12.0mm	-	E20-472(C)	E25-472(C)	E32-472(C)	E40-472(C)
12.5mm	-	E20-492(C)	E25-492(C)	E32-492(C)	E40-492(C)
13.0mm	-	E20-511(C)	E25-511(C)	E32-511(C)	E40-511(C)
13.5mm	-	-	E25-531(C)	E32-531(C)	E40-531(C)
14.0mm	-	-	E25-551(C)	E32-551(C)	E40-551(C)
14.5mm	-	-	E25-570(C)	E32-570(C)	E40-570(C)
15.0mm	-	-	E25-590(C)	E32-590(C)	E40-590(C)
15.5mm	-	-	E25-610(C)	E32-610(C)	E40-610(C)
16.0mm	-	-	E25-629(C)	E32-629(C)	E40-629(C)
16.5mm	-	-	-	E32-649(C)	E40-649(C)
17.0mm	-	-	-	E32-669(C)	E40-669(C)
17.5mm	-	-	-	E32-688(C)	E40-688(C)
18.0mm	-	-	-	E32-708(C)	E40-708(C)
18.5mm	-	-	-	E32-728(C)	E40-728(C)
19.0mm	-	-	-	E32-748(C)	E40-748(C)
19.5mm	-	-	-	E32-767(C)	E40-767(C)
20.0mm	-	-	-	E32-787(C)	E40-787(C)
20.5mm	-	-	-	-	E40-807(C)
21.0mm	-	-	-	-	E40-826(C)
21.5mm	-	-	-	-	E40-846(C)
22.0mm	-	-	-	-	E40-866(C)
22.5mm	-	-	-	-	E40-885(C)
23.0mm	-	-	-	-	E40-905(C)
23.5mm	-	-	-	-	E40-925(C)
24.0mm	-	-	-	-	E40-944(C)
24.5mm	-	-	-	-	E40-964(C)
25.0mm	-	-	-	-	E40-984(C)
25.5mm	-	-	-	-	E40-1003(C)
26.0mm	-	-	-	-	E40-1023(C)



# B Tap Collets

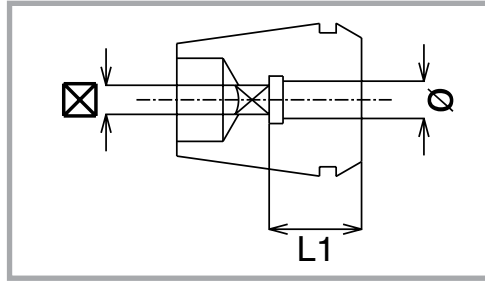

ER Tap Collets feature a unique design that incorporates an internal square drive with our popular ER Series collets. The square drive matches the tap square, providing a tight fit for all rigid tapping applications.

PART NUMBER	TAP INCH SIZE	TAP METRIC SIZE	L1	Ø	⊠
ET16-168	⊘, 5/32"	M4	18.0mm	0.168	0.131
ET16-194	#0, 3/16"	M4.5, M5	18.0mm	0.194	0.152
ET16-220	#2, 7/32"	-	18.0mm	0.220	0.165
ET16-255	#4, 1/4"	M6, M6.5	18.0mm	0.255	0.191
ET20-168	⊘, 5/32"	M4	18.0mm	0.168	0.131
ET20-194	#0, 3/16"	M4.5, M5	18.0mm	0.194	0.152
ET20-220	#2, 7/32"	-	18.0mm	0.220	0.165
ET20-255	#4, 1/4"	M6, M6.5	18.0mm	0.255	0.191
ET20-318	5/16"	M7, M6.5	18.0mm	0.318	0.238
ET20-323	7/16"	-	18.0mm	0.323	0.242
ET20-367	1/2"	M12, M12.5	18.0mm	0.367	0.275
ET20-381	3/8"	M10	18.0mm	0.381	0.286
ET25-168	⊘, 5/32"	M4	18.0mm	0.168	0.131
ET25-194	#0, 3/16"	M4.5, M5	18.0mm	0.194	0.152
ET25-220	#2, 7/32"	-	18.0mm	0.220	0.165
ET25-255	#4, 1/4"	M6, M6.5	18.0mm	0.255	0.191
ET25-318	5/16"	M7, M6.5	18.0mm	0.318	0.238
ET25-323	7/16"	-	18.0mm	0.323	0.242
ET25-367	1/2"	M12, M12.5	18.0mm	0.367	0.275
ET25-381	3/8"	M10	18.0mm	0.381	0.286
ET25-429	9/16"	M14	22.0mm	0.429	0.322
ET25-437	1/8" NPT(L)	-	22.0mm	0.437	0.328
ET25-480	5/8"	M16	25.0mm	0.480	0.360
ET32-168	⊘, 5/32"	M4	18.0mm	0.168	0.131
ET32-194	#0, 3/16"	M4.5, M5	18.0mm	0.194	0.152
ET32-220	#2, 7/32"	-	18.0mm	0.220	0.165
ET32-255	#4, 1/4"	M6, M6.5	18.0mm	0.255	0.191
ET32-318	5/16"	M7, M6.5	18.0mm	0.318	0.238
ET32-323	7/16"	-	18.0mm	0.323	0.242
ET32-367	1/2"	M12, M12.5	18.0mm	0.367	0.275
ET32-381	3/8"	M10	18.0mm	0.381	0.286
ET32-429	9/16"	M14	22.0mm	0.429	0.322
ET32-437	1/8" NPT	-	22.0mm	0.437	0.328
ET32-480	5/8"	M16	25.0mm	0.480	0.360
ET32-542	11/16"	M18	25.0mm	0.542	0.406
ET32-562	1/4" NPT	-	25.0mm	0.562	0.421
ET32-590	3/4"	-	25.0mm	0.590	0.422
ET32-652	13/16"	M20	25.0mm	0.652	0.489
ET40-255	#4, 1/4"	M6, M6.5	18.0mm	0.255	0.191
ET40-318	5/16"	M7, M6.5	18.0mm	0.318	0.238
ET40-323	7/16"	-	18.0mm	0.323	0.242
ET40-367	1/2"	M12, M12.5	18.0mm	0.367	0.275
ET40-381	3/8"	M10	18.0mm	0.381	0.286
ET40-429	9/16"	M14	22.0mm	0.429	0.322
ET40-437	1/8" NPT	-	22.0mm	0.437	0.328
ET40-480	5/8"	M16	25.0mm	0.480	0.360
ET40-542	11/16"	M18	25.0mm	0.542	0.406
ET40-562	1/4" NPT	-	25.0mm	0.562	0.421
ET40-590	3/4"	-	25.0mm	0.590	0.422
ET40-652	13/16"	M20	25.0mm	0.652	0.489
ET40-687	1/2" NPT	-	25.0mm	0.687	0.515
ET40-697	7/8"	M22	25.0mm	0.697	0.523
ET40-700	3/8" NPT	-	25.0mm	0.700	0.531
ET40-760	15/16"	M24	25.0mm	0.760	0.570
ET40-800	1"	M25	28.0mm	0.800	0.600

# B Tap Coolant Collets

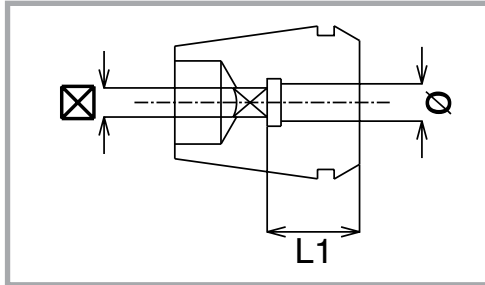

Lyndex-Nikken has now combined the versatility of our ER tapping collets with the popularity of our coolant collets to create our patented ER Coolant Tap Collets.

PART NUMBER	TAP INCH SIZE	TAP METRIC SIZE	L1	Ø	☒
ET16-255(C)	#4, 1/4"	M6, M6.5	18.0mm	0.255	0.191
ET16-318(C)	5/16"	M7, M6.5	18.0mm	0.318	0.238
ET20-255(C)	#4, 1/4"	M6, M6.5	18.0mm	0.255	0.191
ET20-318(C)	5/16"	M7, M6.5	18.0mm	0.318	0.238
ET20-323(C)	7/16"	-	18.0mm	0.323	0.242
ET20-367(C)	1/2"	M12, M12.5	18.0mm	0.367	0.275
ET20-381(C)	3/8"	M10	18.0mm	0.381	0.286
ET25-318(C)	5/16"	M7, M6.5	18.0mm	0.318	0.238
ET25-323(C)	7/16"	-	18.0mm	0.323	0.242
ET25-367(C)	1/2"	M12, M12.5	18.0mm	0.367	0.275
ET25-381(C)	3/8"	M10	18.0mm	0.381	0.286
ET25-429(C)	9/16"	M14	22.0mm	0.429	0.322
ET25-480(C)	5/8"	M16	25.0mm	0.480	0.360
ET32-255(C)	#4, 1/4"	M6, M6.5	18.0mm	0.255	0.191
ET32-318(C)	5/16"	M7, M6.5	18.0mm	0.318	0.238
ET32-323(C)	7/16"	-	18.0mm	0.323	0.242
ET32-367(C)	1/2"	M12, M12.5	18.0mm	0.367	0.275
ET32-381(C)	3/8"	M10	18.0mm	0.381	0.286
ET32-429(C)	9/16"	M14	22.0mm	0.429	0.322
ET32-480(C)	5/8"	M16	25.0mm	0.480	0.360
ET32-542(C)	11/16"	M18	25.0mm	0.542	0.406
ET32-590(C)	3/4"	-	25.0mm	0.590	0.422
ET32-652(C)	13/16"	M20	25.0mm	0.652	0.489
ET40-323(C)	7/16"	-	18.0mm	0.323	0.242
ET40-367(C)	1/2"	M12, M12.5	18.0mm	0.367	0.275
ET40-381(C)	3/8"	M10	18.0mm	0.381	0.286
ET40-429(C)	9/16"	M14	22.0mm	0.429	0.322
ET40-480(C)	5/8"	M16	25.0mm	0.480	0.360
ET40-542(C)	11/16"	M18	25.0mm	0.542	0.406
ET40-590(C)	3/4"	-	25.0mm	0.590	0.422
ET40-652(C)	13/16"	M20	25.0mm	0.652	0.489
ET40-697(C)	7/8"	M22	25.0mm	0.697	0.523
ET40-760(C)	15/16"	M24	25.0mm	0.760	0.570
ET40-800(C)	1"	M25	28.0mm	0.800	0.600

Note: Seals up to maximum coolant pressure of 1000 PSI.

## Collet Chuck DIN 6499 - Type ER

Short type, clamping nut inside

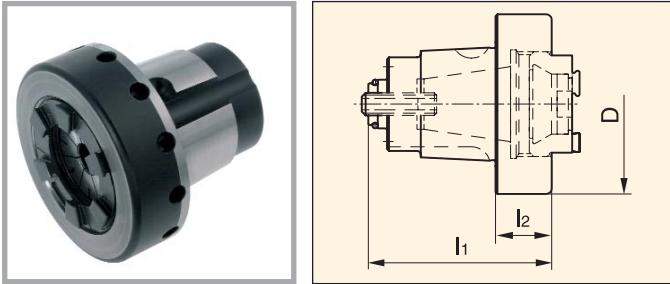

Part Number	Size	Collet	I1	I2	D
121479	MI32	ER11	1.634"	0.591"	1.654"
155357	MI32	ER16	1.634"	0.591"	1.654"
155388	MI40	ER16	1.772"	0.433"	1.890"
155335	MI40	ER20	1.929"	0.591"	1.890"
155367	MI40	ER25	2.165"	0.827"	1.890"
155418	MI50	ER25	2.165"	0.551"	2.283"
155460	MI50	ER32	2.323"	0.709"	2.283"
155471	MI63	ER32	2.480"	0.551"	2.953"
155496	MI63	ER40	2.717"	0.787"	2.953"

Long type, clamping nut outside

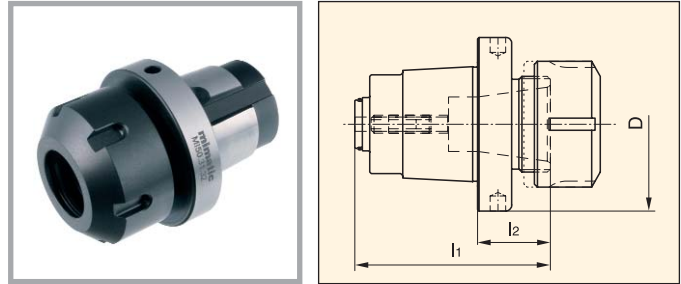

Part Number	Size	Collet	I1	I2	D
155358	MI32	ER11	2.461"	1.417"	1.654"
155319	MI32	ER16	1.988"	0.945"	1.654"
121460	MI40	ER16	2.283"	0.945"	1.890"
121502	MI40	ER20	2.520"	1.181"	1.890"
155448	MI50	ER25	2.571"	1.614"	2.283"
155445	MI50	ER32	2.835"	1.850"	2.283"
155475	MI63	ER32	3.150"	1.850"	2.953"
155451	MI63	ER40	3.307"	0.791"	2.953"

## Combination Shell End Mill Arbor

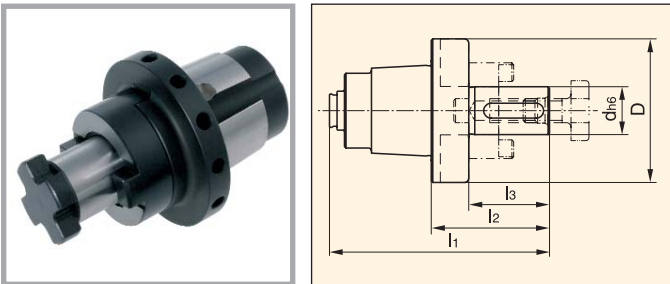

Part Number	Size	I1	I1	I3	d(h6)	D
121486	MI32	2.598"	1.555"	1.063"	16mm (.630")	1.654"
155365	MI40	2.894"	1.555"	0.984"	16mm (.630")	1.890"
155447	MI50	3.228"	1.614"	1.063"	16mm (.630")	2.283"
155413	MI50	3.465"	1.850"	1.220"	22mm (.866")	2.283"
SM3/4	MI50	3.150"	1.496"	1.260"	.750" (3/4")	2.283"
155512	MI63	3.780"	1.850"	1.220"	22mm (.866")	2.953"
155465	MI63	3.858"	1.929"	1.299"	27mm (1.063")	2.953"



## Weldon Toolholder DIN 1835 B

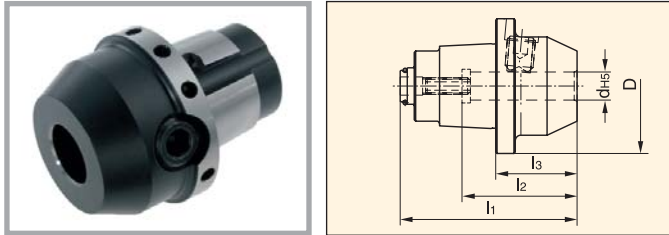

Part Number	Size	I1	I2	I3	d(H5)	D
121436	MI32	2.067"	1.457"	1.024"	6	1.654"
121478	MI32	2.067"	1.457"	1.024"	8	1.654"
121469	MI32	2.185"	1.614"	1.142"	10	1.654"
121439	MI32	2.264"	1.811"	1.220"	12"	1.654"
121449	MI32	2.067"	1.457"	1.024"	1/4"	1.654"
121472	MI32	2.185"	1.614"	1.142"	3/8"	1.654"
121448	MI32	2.264"	1.811"	1.220"	1/2"	1.654"
155330	MI40	2.362"	1.457"	1.024"	6	1.890"
155346	MI40	2.362"	1.457"	1.024"	8	1.890"
155321	MI40	2.480"	1.614"	1.142"	10	1.890"
155331	MI40	2.559"	1.811"	1.220"	12	1.890"
155326	MI40	2.559"	1.811"	1.220"	14	1.890"
155379	MI40	2.677"	1.929"	1.339"	16	1.890"
121497	MI40	2.362"	1.457"	1.024"	1/4"	1.890"
121475	MI40	2.480"	1.614"	1.142"	3/8"	1.890"
121474	MI40	2.559"	1.811"	1.220"	1/2"	1.890"
121499	MI40	2.677"	1.929"	1.339"	5/8"	1.890"
155419	MI50	2.559"	1.457"	0.945"	6	2.283"
155411	MI50	2.598"	1.614"	0.984"	8	2.283"
155400	MI50	2.756"	1.811"	1.142"	10	2.283"
155406	MI50	2.874"	1.929"	1.260"	12	2.283"
155412	MI50	2.874"	1.457"	1.260"	14	2.283"
155407	MI50	2.913"	1.614"	1.299"	16	2.283"
155427	MI50	3.071"	1.811"	1.457"	20	2.283"
121489	MI50	2.559"	1.457"	0.945"	1/4"	2.283"
121529	MI50	1.575"	1.614"	1.142"	3/8"	2.283"
121525	MI50	2.874"	1.811"	1.260"	1/2"	2.283"
121520	MI50	2.953"	1.929"	1.339"	5/8"	2.283"
121526	MI50	3.071"	2.008"	1.457"	3/4"	2.283"
155470	MI63	3.189"	1.457"	1.457"	6	2.953"
155459	MI63	3.228"	1.457"	1.457"	8	2.953"
155490	MI63	3.346"	1.614"	1.417"	10	2.953"
155509	MI63	3.484"	1.811"	1.535"	12	2.953"
155463	MI63	3.484"	1.811"	1.535"	14	2.953"
155482	MI63	3.583"	1.929"	1.654"	16	2.953"
155474	MI63	3.661"	2.008"	1.732"	20	2.953"
155464	MI63	4.331"	2.323"	2.402"	25	2.953"
166815	MI63	3.189"	1.457"	1.260"	1/4"	2.953"
166805	MI63	3.346"	1.614"	1.417"	3/8"	2.953"
166813	MI63	3.484"	1.811"	1.555"	1/2"	2.953"
166807	MI63	3.583"	1.929"	1.654"	5/8"	2.953"
166804	MI63	3.661"	2.008"	1.732"	3/4"	2.953"
166812	MI63	4.331"	2.323"	2.402"	1"	2.953"

## Whistle Notch Toolholder DIN 1835 E

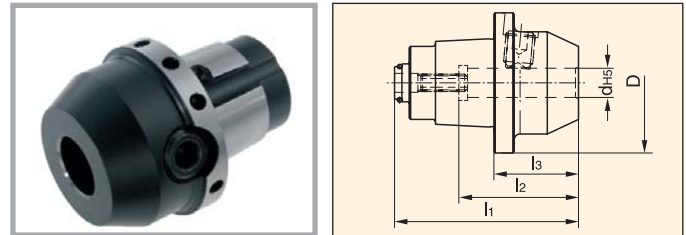

Part Number	Size	I1	I2	I3	d(H5)	D
121463	MI32	2.067"	1.417"	1.024"	6	1.654"
121464	MI32	2.067"	1.417"	1.024"	8	1.654"
121443	MI32	2.185"	1.575"	1.142"	10	1.654"
121453	MI32	2.264"	1.772"	1.220"	12	1.654"
121442	MI32	2.067"	1.417"	1.024"	1/4"	1.654"
121485	MI32	2.185"	1.575"	1.142"	3/8"	1.654"
121480	MI32	2.264"	1.772"	1.220"	1/2"	1.654"
155369	MI40	2.362"	1.417"	1.024"	6	1.890"
155363	MI40	2.362"	1.417"	1.024"	8	1.890"
155370	MI40	2.480"	1.575"	1.142"	10	1.890"
155364	MI40	2.559"	1.772"	1.220"	12	1.890"
155333	MI40	2.559"	1.772"	1.220"	14	1.890"
155382	MI40	2.677"	1.890"	1.339"	16	1.890"
121492	MI40	2.362"	1.417"	1.024"	1/4"	1.890"
121493	MI40	2.480"	1.575"	1.142"	3/8"	1.890"
121455	MI40	2.559"	1.772"	1.220"	1/2"	1.890"
121494	MI40	2.677"	1.890"	1.339"	5/8"	1.890"
155416	MI50	2.559"	1.417"	0.945"	6	2.283"
155401	MI50	2.598"	1.417"	0.984"	8	2.283"
155383	MI50	2.756"	1.575"	1.142"	10	2.283"
155408	MI50	2.874"	1.772"	1.260"	12	2.283"
155435	MI50	2.874"	1.772"	1.260"	14	2.283"
155436	MI50	2.972"	1.890"	1.358"	16	2.283"
155384	MI50	3.071"	1.969"	1.457"	20	2.283"
166816	MI50	2.559"	1.417"	0.945"	1/4"	2.283"
155440	MI50	2.756"	1.575"	1.142"	3/8"	2.283"
155434	MI50	2.874"	1.772"	1.260"	1/2"	2.283"
155428	MI50	2.953"	1.890"	1.339"	5/8"	2.283"
155385	MI50	3.071"	1.969"	1.457"	3/4"	2.283"
166104	MI63	3.189"	1.417"	1.260"	6	2.953"
166105	MI63	3.228"	1.417"	1.299"	8	2.953"
166110	MI63	3.346"	1.575"	1.417"	10	2.953"
166112	MI63	3.484"	1.772"	1.555"	12	2.953"
166113	MI63	3.484"	1.772"	1.555"	14	2.953"
166114	MI63	3.583"	1.890"	1.654"	16	2.953"
166115	MI63	3.661"	1.969"	1.732"	20	2.953"
166116	MI63	4.331"	2.205"	2.402"	25	2.953"
166797	MI63	3.189"	1.417"	1.260"	1/4"	2.953"
166799	MI63	3.346"	1.575"	1.417"	3/8"	2.953"
166796	MI63	3.484"	1.772"	1.555"	1/2"	2.953"
166803	MI63	3.583"	1.890"	1.654"	5/8"	2.953"
166798	MI63	3.661"	1.969"	1.732"	3/4"	2.953"
166795	MI63	4.331"	2.205"	2.402"	1"	2.953"

## SYNTAX® Tapping Quick Change Holder

without internal coolant,  
with synchronization and length  
compensation

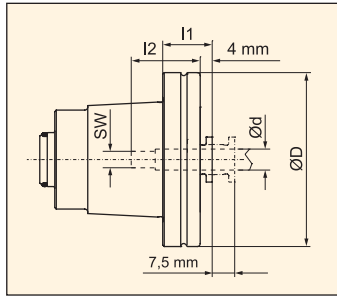

Part Number	Size	L1	L2	d	D	SW
121510	MI40	0.669"	0.984"	3.5mm (.138")	1.890"	0.106"
155397	MI40	0.669"	0.984"	4.5mm (.177")	1.890"	0.134"
155377	MI40	0.669"	1.063"	6mm (.236")	1.890"	0.193"
155378	MI40	0.669"	1.063"	8mm (.315")	1.890"	0.244"
155403	MI40	1.496"	1.102"	9mm (.354")	1.890"	0.276"
121451	MI40	1.496"	1.142"	10mm (.394")	1.890"	0.315"
121498	MI40	1.496"	1.181"	12mm (.472")	1.890"	0.354"
155450	MI50	0.650"	0.984"	3.5mm (.138")	2.283"	0.106"
155487	MI50	0.650"	0.984"	4.5mm (.177")	2.283"	0.134"
155422	MI50	0.650"	1.063"	6mm (.236")	2.283"	0.193"
155455	MI50	0.650"	1.063"	8mm (.315")	2.283"	0.244"
155423	MI50	0.650"	1.102"	9mm (.354")	2.283"	0.276"
155466	MI50	0.650"	1.142"	10mm (.394")	2.283"	0.315"
155449	MI50	0.650"	1.181"	12mm (.472")	2.283"	0.354"
155479	MI50	1.732"	1.299"	16mm (.630")	2.283"	0.472"

with internal coolant (70 bar),  
only synchronization

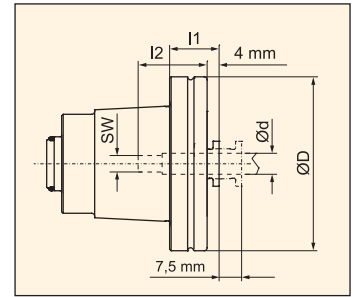

Part Number	Size	L1	L2	d	D	SW
155389	MI40	0.669"	1.063"	6mm (.236")	1.890"	0.193"
121522	MI40	0.669"	1.063"	8mm (.315")	1.890"	0.244"
121515	MI40	1.496"	1.102"	9mm (.354")	1.890"	0.276"
121504	MI40	1.496"	1.142"	10mm (.394")	1.890"	0.315"
121517	MI40	1.496"	1.181"	12mm (.472")	1.890"	0.354"
155432	MI50	0.650"	1.063"	6mm (.236")	2.283"	0.193"
155498	MI50	0.650"	1.063"	8mm (.315")	2.283"	0.244"
155473	MI50	0.650"	1.102"	9mm (.354")	2.283"	0.276"
155467	MI50	0.650"	1.142"	10mm (.394")	2.283"	0.315"
155446	MI50	0.650"	1.181"	12mm (.472")	2.283"	0.354"
121534	MI50	1.732"	1.299"	16mm (.630")	2.283"	0.472"

## Quick Change AngleHeads™

Part Number	Description
MI50-STA-#	# Synax Tap Adapter
MI50-STA-#	# Synax Tap Adapter
MI50-STA-#0	#0 Synax Tap Adapter
MI50-STA-#2	#2 Synax Tap Adapter
MI50-STA-1/4	1/4 Synax Tap Adapter
MI50-STA-5/16	5/16 Synax Tap Adapter
MI50-STA-3/8	3/8 Synax Tap Adapter
MI50-STA-7/16	7/16 Synax Tap Adapter
MI50-STA-1/2	1/2 Synax Tap Adapter
MI50-STA-9/16	9/16 Synax Tap Adapter
MI50-STA-5/8	5/8 Synax Tap Adapter

## Softsynchro Chuck (Licence Emuge)

with internal coolant,  
with push and pull length  
compensation 0.5mm

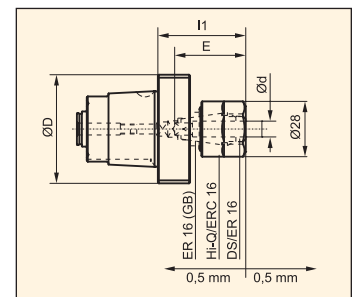

Part Number	Size	Collet	Thread	L1	d	D
121503	MI40	ER-GB16	M4-M12	1.870"	.177-.394"	1.772"
121530	MI50	ER-GB16	M4-M12	1.752"	.177-.394"	1.969"

## Accessories for Hydraulic Chucks

Sleeve

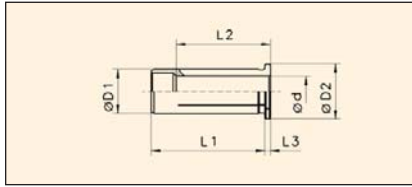

Part Number	D1	d(h6)	I1	I2	I3	D2
119790	0.472"	3	1.575"	1.142"	0.157"	0.630"
119793	0.472"	1/8"	1.575"	1.142"	0.157"	0.630"
119797	0.472"	4	1.575"	1.142"	0.157"	0.630"
119798	0.472"	3/16"	1.575"	1.142"	0.157"	0.630"
119819	0.472"	5	1.575"	1.142"	0.157"	0.630"
119812	0.472"	6	1.575"	1.417"	0.157"	0.630"
119813	0.472"	1/4"	1.575"	1.417"	0.157"	0.630"
119791	0.472"	7	1.575"	1.457"	0.157"	0.630"
119799	0.472"	5/16"	1.575"	1.457"	0.157"	0.630"
119810	0.472"	8	1.575"	1.457"	0.157"	0.630"
119792	0.472"	9	1.575"	1.457"	0.157"	0.630"
119815	0.472"	3/8"	1.575"	1.575"	0.157"	0.630"
119814	0.472"	10	1.575"	1.575"	0.157"	0.630"
119816	0.787"	3	1.969"	1.102"	0.157"	0.984"
119823	0.787"	1/8"	1.969"	1.102"	0.157"	0.984"
119817	0.787"	4	1.969"	1.102"	0.157"	0.984"
119837	0.787"	3/16"	1.969"	1.102"	0.157"	0.984"
119800	0.787"	5	1.969"	1.102"	0.157"	0.984"
119801	0.787"	6	1.969"	1.417"	0.157"	0.984"
119822	0.787"	1/4"	1.969"	1.417"	0.157"	0.984"
119818	0.787"	7	1.969"	1.496"	0.157"	0.984"
119839	0.787"	5/16"	1.969"	1.457"	0.157"	0.984"
119820	0.787"	8	1.969"	1.457"	0.157"	0.984"
119802	0.787"	9	1.969"	1.496"	0.157"	0.984"
119838	0.787"	3/8"	1.969"	1.496"	0.157"	0.984"
119824	0.787"	10	1.969"	1.575"	0.157"	0.984"
119825	0.787"	11	1.969"	1.575"	0.157"	0.984"
119830	0.787"	7/16"	1.969"	1.772"	0.157"	0.984"
119826	0.787"	12	1.969"	1.772"	0.157"	0.984"
119821	0.787"	1/2"	1.969"	1.772"	0.157"	0.984"
119827	0.787"	14	1.969"	1.772"	0.157"	0.984"
119846	0.787"	9/16"	1.969"	1.772"	0.157"	0.984"
119829	0.787"	5/8"	1.969"	1.890"	0.157"	0.984"
119828	0.787"	16	1.969"	1.890"	0.157"	0.984"
119847	0.984"	3	2.205"	1.142"	0.157"	1.181"
119848	0.984"	4	2.205"	1.142"	0.157"	1.181"
119831	0.984"	5	2.205"	1.142"	0.157"	1.181"
119849	0.984"	6	2.205"	1.457"	0.157"	1.181"
119832	0.984"	7	2.205"	1.457"	0.157"	1.181"
119833	0.984"	8	2.205"	1.457"	0.157"	1.181"
119834	0.984"	9	2.205"	1.496"	0.157"	1.181"
119850	0.984"	10	2.205"	1.575"	0.157"	1.181"
119835	0.984"	12	2.205"	1.811"	0.157"	1.181"

Part Number	D1	d(h6)	I1	I2	I3	D2
119851	0.984"	14	2.205"	1.850"	0.157"	1.181"
119836	0.984"	16	2.205"	1.890"	0.157"	1.181"
119841	0.984"	18	2.205"	1.890"	0.157"	1.181"
119842	0.984"	20	2.205"	1.969"	0.157"	1.181"
119844	1.260"	6	2.362"	1.417"	0.157"	1.417"
119857	1.260"	1/4"	2.362"	1.417"	0.157"	1.417"
119845	1.260"	7	2.362"	1.457"	0.157"	1.417"
119879	1.260"	5/16"	2.362"	1.417"	0.157"	1.417"
119852	1.260"	8	2.362"	1.417"	0.157"	1.417"
119855	1.260"	9	2.362"	1.457"	0.157"	1.417"
119884	1.260"	3/8"	2.362"	1.457"	0.157"	1.417"
119864	1.260"	10	2.362"	1.575"	0.157"	1.417"
119853	1.260"	11	2.362"	1.575"	0.157"	1.417"
119858	1.260"	12	2.362"	1.772"	0.157"	1.417"
119856	1.260"	1/2"	2.362"	1.772"	0.157"	1.417"
119859	1.260"	3/16"	2.362"	1.772"	0.157"	1.417"
119865	1.260"	14	2.362"	1.811"	0.157"	1.417"
119854	1.260"	15/16"	2.362"	1.811"	0.157"	1.417"
119861	1.260"	5/8"	2.362"	1.811"	0.157"	1.417"
119866	1.260"	16	2.362"	1.890"	0.157"	1.417"
119870	1.260"	18	2.362"	1.929"	0.157"	1.417"
119878	1.260"	3/4"	2.362"	1.969"	0.157"	1.417"
119877	1.260"	20	2.362"	1.969"	0.157"	1.417"
119867	1.260"	25	2.362"	2.205"	0.157"	1.417"

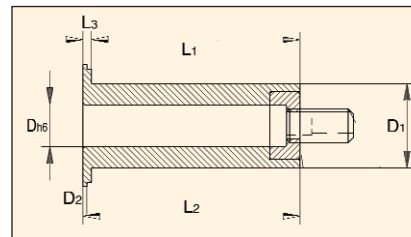

with horizontal adjustment

Part Number	D1	d(h6)	I1	I2	I3	D2
119909	0.787"	6	1.969"	2.047"	-	1.102"
119889	0.787"	8	1.969"	2.047"	-	1.102"
152696	0.787"	10	1.969"	2.047"	-	1.102"
119910	0.787"	12	1.969"	2.047"	-	1.102"
119901	0.787"	14	1.969"	2.047"	-	1.102"
119911	0.787"	16	1.969"	2.047"	-	1.102"
119892	0.787"	18	1.969"	2.047"	-	1.102"
119893	0.984"	10	2.205"	2.323"	-	1.260"
119912	0.984"	12	2.205"	2.323"	-	1.260"
119894	0.984"	14	2.205"	2.323"	-	1.260"
119895	0.984"	16	2.205"	2.323"	-	1.260"
167144	0.984"	18	2.205"	2.323"	-	1.260"
167045	0.984"	20	2.205"	2.323"	-	1.260"

## Shrink Fit Chuck

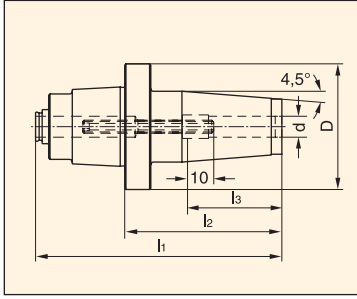

Part Number	Size	I1	I2	I3	d(h6)	D
155381	MI40	3.701"	2.362"	1.417"	8mm (.315")	1.890"
121482	MI40	3.701"	2.362"	1.654"	10mm (.394")	1.890"
155334	MI40	3.898"	2.559"	1.850"	12mm (.472")	1.890"
121501	MI40	4.094"	2.756"	1.969"	16mm (.630")	1.890"
155421	MI50	3.976"	2.362"	1.417"	8mm (.315")	2.283"
155409	MI50	3.976"	2.362"	1.654"	10mm (.394")	2.283"
155444	MI50	4.137"	2.559"	1.850"	12mm (.472")	2.283"
155438	MI50	4.137"	2.559"	1.850"	14mm (.551")	2.283"
155430	MI50	4.370"	2.756"	1.969"	16mm (.630")	2.283"
155431	MI50	4.567"	2.953"	1.969"	18mm (.709")	2.283"
155454	MI50	4.567"	2.953"	2.047"	20mm (.787")	2.283"

## Blank

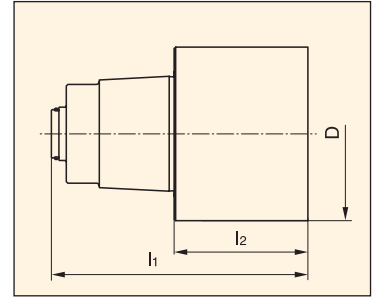

Part Number	Size	I1	I2	D
121457	MI32	3.012"	1.969"	1.654"
166791	MI40	3.701"	2.362"	1.890"
166789	MI50	4.370"	2.756"	2.283"
121557	MI63	5.079"	3.150"	2.953"

## Hydraulic Chuck

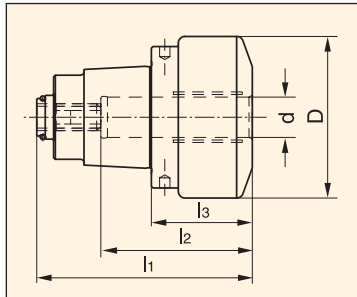

Part Number	Size	I1	I2	I3	d(h6)	D
155391	MI40	2.520"	1.772"	1.181"	12mm (.472")	1.890"
155417	MI50	2.795"	2.047"	1.181"	20mm (.787")	2.283"

## Tool Presetting Unit

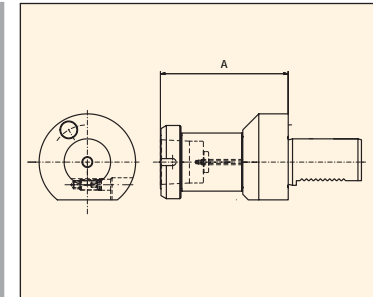

Part Number	Size	VDI	A
155368	MI40	2.520"	108mm
155356	MI50	2.795"	110mm

# TQW Torque Wrenches



The TQW Torque Wrench is very accurate and easy-to-use, guaranteeing maximum accuracy and preventing tool overtightening or breakage.

- Variable torque adjustable wrench
- Robust and durable
- Ergonomic grip
- Easy to read inch and metric scale
- Strong steel shaft is highly corrosion resistant
- Easy to set up and operation:
  - A. Set wrench to desired torque setting
  - B. Insert attachment
  - C. Torque down on collet nut until it clicks in place

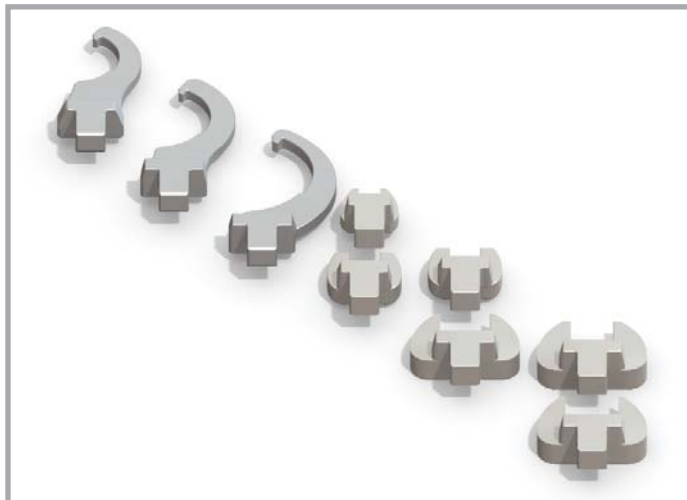

A wide selection of attachments are available: ER, SK, TG, Pull Stud, Milling Chuck, Capto

## Design and Construction



A "Push-Button Locking Device" securely locks the preset torque and prevents inadvertent adjustment.



Handle is shaped to provide a firm and ergonomic grip.

Collet Number	Part Number	Attachments (Type and Size)			Torque Range		Torque Wrench	
		Description	mm	inch	lbs	Nm	Part Number	Description
ER8	TQW-ER08	Blank	Special Attachment - Call		4	6	TQW-025	14X18, 25ft.lbs
ER11	TQW-ER11(17)	Hex/OE	17	0.67	11	15	TQW-150	14X18, 150ft.lbs
ER16	TQW-ER16(32)	Hook	32 [+/-5mm]	1.25	40	54		
ER20	TQW-ER20(32)		32 [+/-5mm]	1.25	60	81		
ER25	TQW-ER25(43)		43 [+/-5mm]	1.69	75	102		
ER32	TQW-ER32(50)		50 [+/-5mm]	1.96	100	136		
ER40	TQW-ER40(63)		63 [+/-5mm]	2.48	125	169		
SK6	TQW-SK06(18)		Hex/OE	18	0.71	14		
SK10	TQW-SK10(1)	Hook	25.4	1.00	33-34	45-46	TQW-150	14X18, 150ft.lbs
SK16	TQW-SK16(43)		43 [+/-5mm]	1.69	55-62	74-84		
SK25	TQW-SK25(60)		60 [+/-5mm]	2.36	66-73	90-99		
TG75	TQW-TG075(50)	Hook	50 [+/-5mm]	1.96	55	75	TQW-150	14X18, 150ft.lbs
TG100	TQW-TG100(63)		63 [+/-5mm]	2.48	75	102		
TG150	TQW-TG150(82)		82 [+/-5mm]	3.22	100	136		
Pull-Stud-13mm	TQW-PS(13)	Hex/OE	13	0.51	14 ~ 18	19 to 25	TQW-025	14X18, 25ft.lbs
Pull-Stud-3/4 (19mm)	TQW-PS(19)		19	0.75	44 ~ 59	60 to 80	TQW-150	14X18, 150ft.lbs
Pull-Stud-30mm	TQW-PS(30)		30	1.18	147 ~ 185	200 to 250		
Pull-Stud-1.1/4	TQW-PS(32)		31.75	1/1/2004	147 ~ 185	200 to 250		
Milling Chuck 3/4"	TQW-C3/4(50)	Hook	50 [+/-5mm]	1.96	19 to 24	26-32	TQW-150	14X18, 150ft.lbs
Milling Chuck 1"	TQW-C1(60)		60 [+/-5mm]	2.36	27 to 31	36-42		
Milling Chuck 1.1/4"	TQW-C1/4(72)		72 [+/-5mm]	2.83	48 to 59	65-80		
Capto C3	TQW-CAPTO3(8)	Hex	8	0.31	26	35	TQW-150	14X18, 150ft.lbs
Capto C4	TQW-CAPTO4(10)		10	0.39	37	50		
Capto C5	TQW-CAPTO5(12)		12	0.47	52	70		

## Wrench Instructions



**1** Insert spindle wrench behind collet nut. Align spindle wrench with the wrench flats on the spindle.

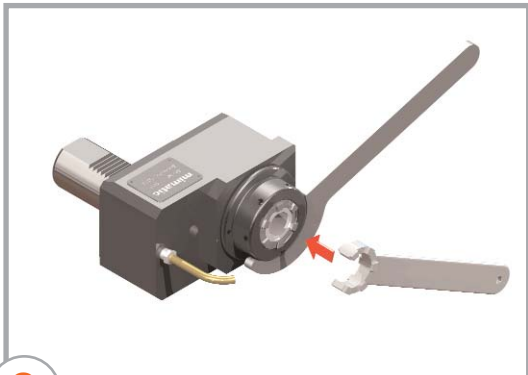

**2** After securing spindle wrench in position, apply collet nut wrench onto collet nut.



**3** While holding the spindle wrench firmly, turn the collet nut wrench clockwise to tighten.

## Service and Support

Lyndex-Nikken is dedicated to providing not only the highest quality of equipment, but also the highest quality of service and customer care. With over 60 years of experience, our service engineers are looking forward to supporting your needs beyond your expectations.

We fully stock all internal components to provide an expedited and cost-effective maintenance program and rebuild package for your live tooling. Managing a maintenance schedule for all your machine tool accessory components can be challenging, so we'll be glad to remind you when the time comes.

Furthermore, to prevent an interruption in your production schedule, for certain models we can offer a "loaner" live tool while your live tool is under repair.

### Warranty:

1 year warranty for internal components

2 year manufacturer warranty on external body

For any service request or inquiry, please contact our service department: (847) 367-4800

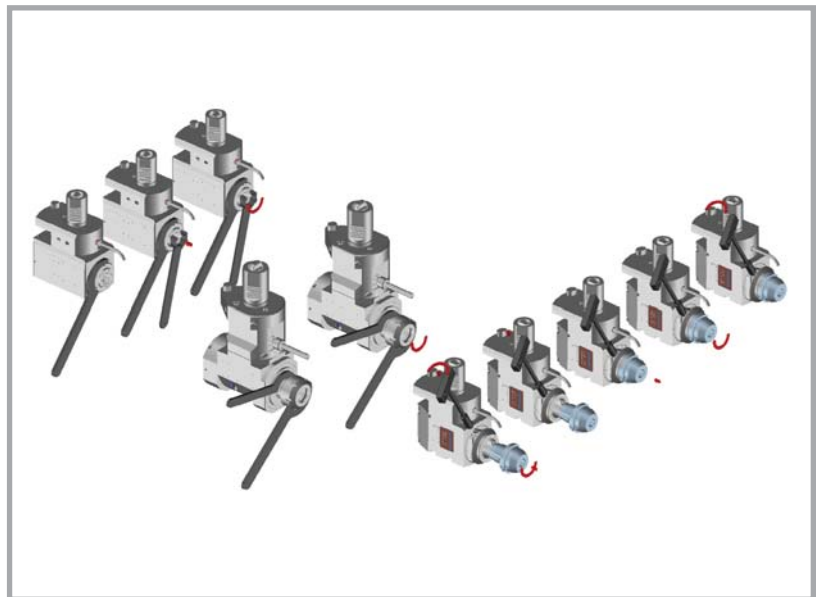



## CNC Rotary Tables

We offer a complete line of extremely accurate Nikken Rotary Tables. Featuring patented hardened assemblies, they retain their precision for years. Please call Lyndex-Nikken for more information: (800) 543-6237.



Worm Wheel System

### Installation Service

Lyndex-Nikken regional managers will assist you with product selection, integration and installation, guaranteeing complete customer satisfaction. Installation service includes drive, cable, table installation, parameter changes and documentation. Call Lyndex-Nikken for more information: (800) 543-6237.



### U.S. Patent 5385424 (Brake System)

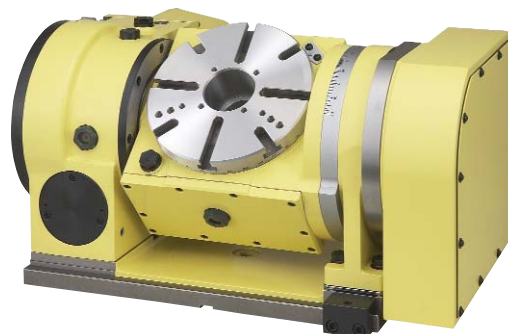

5AX-201

## All-Precision Toolholders

Lyndex-Nikken advanced products are innovatively designed to tackle the most complex and demanding applications. They guarantee a runout within 3 micron at 4 times the diameter beyond collet nut.



## AngleHeads™

Our large range of AngleHeads™ is designed to easily and effectively upgrade your machine tool capabilities by eliminating additional set ups.

Units are equipped with 4340 ground gear and ground shaft components, high precision spindle bearings (P4 quality) and cast iron bodies for vibration dampening. Each tool also features high torque capabilities for aggressive milling and drilling.

Visit [www.lyndexnikken.com](http://www.lyndexnikken.com) to learn more about our complete line of AngleHeads, or call (800) 543-6237.



[www.lyndexnikken.com](http://www.lyndexnikken.com)

(800) 543-6237

CAT2011-MAZAK-MP