

PSC POLYGONAL TURNING PRODUCTS

TAKE YOUR MACHINING TO THE NEXT LEVEL
ISO 26623-1

PSC POLYGONAL TOOLING SYSTEM

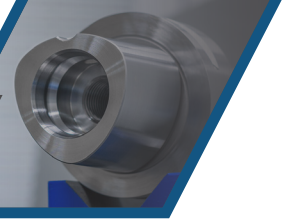



ISO 26623-1

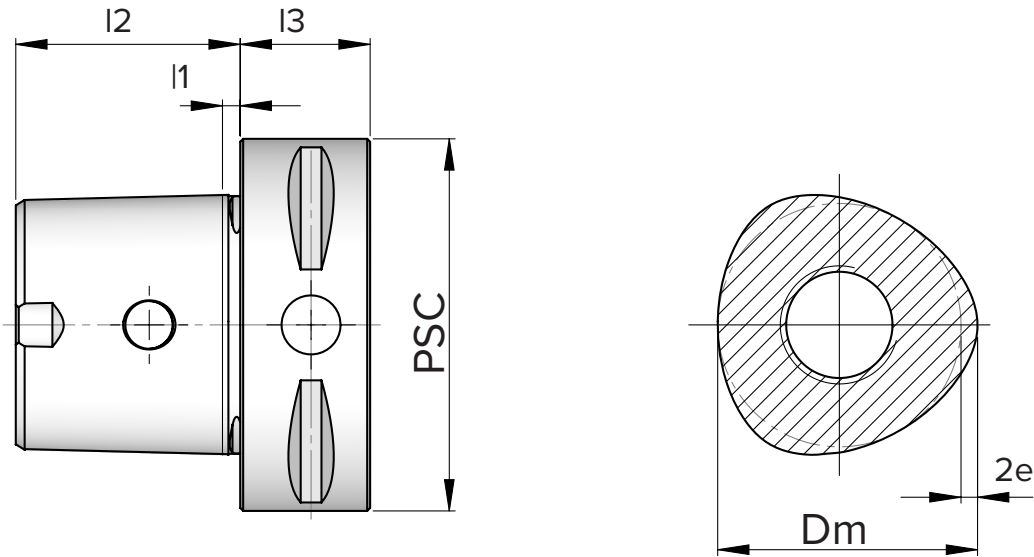

PSC	Size	Dm	e	l1	l2	l3 min.
40	C4	28	0.90	2.50	24	20
50	C5	35	1.12	3.00	30	20
63	C6	44	1.40	3.00	38	22
80	C8	55	2.00	3.00	48	30

Material: Case hardened steel with min. 900 N/mm² of core tensile strength.

Execution: Case hardened 58±2 Hrc. Depth of case 0.6 to 0.8 mm. Black oxidized.

Accuracy: Taper angle AT3 quality class. Roughness Ra < 0.5

All dimensions in this catalogue are in millimeters unless otherwise specified.

PSC POLYGONAL TOOLING SYSTEM

FULL POTENTIAL MACHINING

Polygonal taper tool holders help you bring your machining to a new level



As precisely defined per ISO 26623, PSC interface features unique tapered polygon which serves as a main element in torque transmitting, centering, and clamping. With double contact on both face and taper, as well as great cross-sectional strength, this interface is unrivaled in terms of high clamping force and bending stiffness.

Combination of these excellent properties give PSC interface clear advantage over HSK and 7/24 tapers with about 2x better bending and torsional characteristics. This translates into greater process stability, higher productivity, and lower costs.



Key Attributes of Polygonal Tool Holders:

- Extremely stable and rigid connection between tool and the machine
- High torque and bending forces transmission due to simultaneous tapered polygon and face contact with machine spindle
- Self centering ability due to unique design
- Internal coolant supply, directly to the tool tip
- Best solution for all processes - both in turning and milling
- Modular design for flexible tooling
- Standardized interface as per ISO 26623
- 4 sizes, flange diameters 30-40-50-63-80 mm (sizes C3-C4-C5-C6-C8)

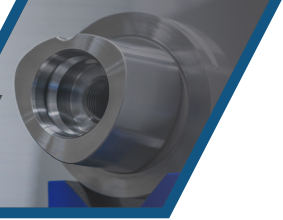

TURNING MADE BETTER

PSC turning tool holders are go-to solution for maximizing process efficiency

Used in both standard turn centers and hybrid mill-turn machines, PSC turning tool holders enable fast tool change solution for reduced down-time and increased productivity without compromise on stability and rigidity. Additionally, direct high pressure coolant nozzles increase tool life with higher feeds and speeds.

More time making chips and less time in unwanted stops makes investment in Polygonal taper tool holders a great choice with a fast return.

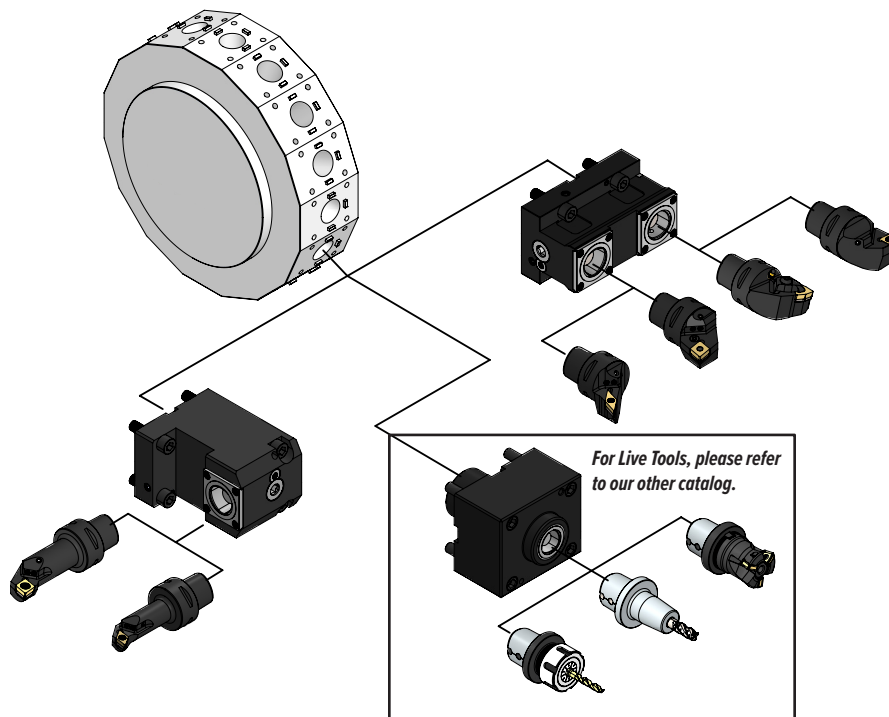

Key Benefits of PSC Turning Tools:

- Reduced setup and tool change time - maximum utilization of the machine
- Increased stability and versatility - in vertical lathes, multi-tasking machining centers and machining centers with turning possibilities
- Ultimate repeatability - allowing online tool presetting
- Reduced tool inventory and storage space in workshop - due to universal interface for both turning and milling
- Self centering system provides high precision and repeatability
- Carbide shims to prevent insert seats from damage
- Quick change, monobloc system without additional interfaces

SHORT ADAPTER DRIVES MORE BENEFITS

Driven and static tools on your machine are best paired with short polygonal taper tool holders

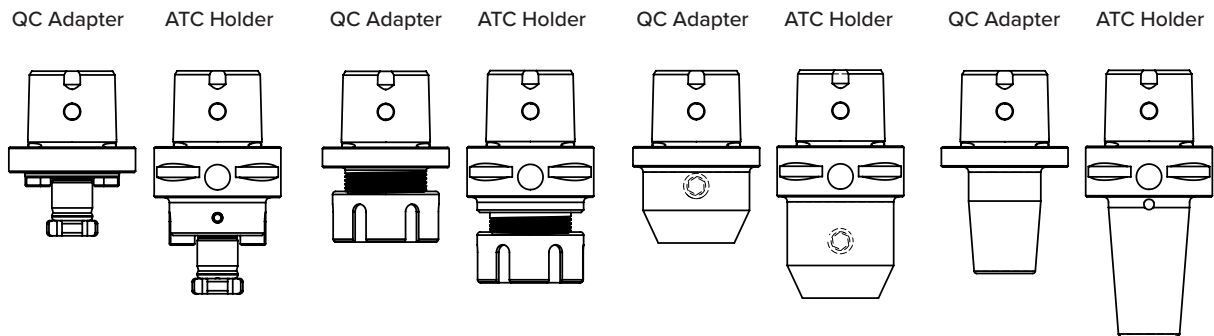

Quick-change PSC adapters have exactly the same ISO 26223-1 taper as normal PSC adapters key with one difference - absence of gripper groove for automatic tool change (ATC). As a result, tool length is reduced which helps achieve stable process hence higher quality parts and more efficient machining.

Key Benefits of Short Adapters:

- Allows for more cutting tool length
- Greater cutting stability
- Extends tool life and accuracy due to reduced tool runout
- Increases surface finish
- Decreases load on driven toolholder bearings
- Reduces setup and tool change time

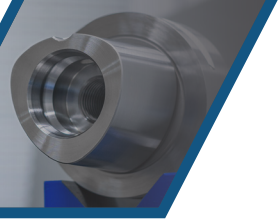

HIGH PRECISION AS STANDARD

In order to ensure highest levels of quality, precision, and compatibility, we manufacture 26623-1 tool holders using the same special inspection and manufacturing equipment and procedures as other major suppliers in the industry.

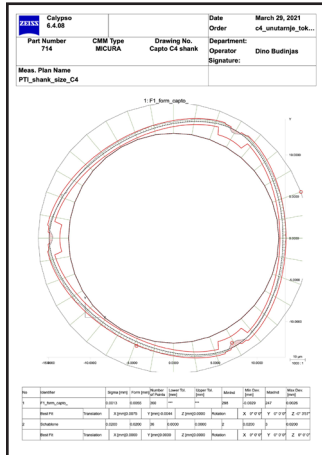

- Laboratory quality certified inspection equipment
- Inspection protocols equal to those of major industry competitors
- State-of-the-art manufacturing equipment
- ISO 9001 certified company
- AUKOM certified quality inspectors
- ISO 26623-1 compliant



PSC POLYGONAL TOOLING SYSTEM

TURNING TOOL HOLDERS - MULTI-FUNCTIONAL

Internal and external
Lever-lock clamp
Direct coolant supply

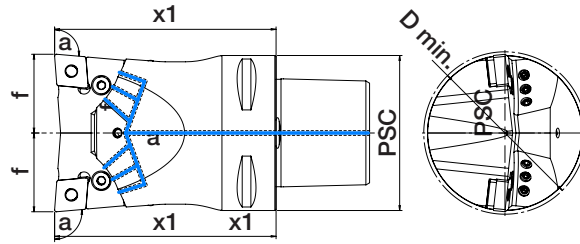

Size	Part Number	Orientation	Insert	PSC	a	x1	f	D min.
C4	C4-TB-CN12CN12-060CP	Multi	CNM..1204..	40	95°	60	21	43
C5	C5-TB-CN12CN12-075CP	Multi	CNM..1204..	50	95°	75	26	53
C6	C6-TB-CN12CN12-090CP	Multi	CNM..1204..	63	95°	90	32	66

	Lever	Lever Screw	Shim	Shim Pin	Nozzle
Spare Parts					
Part #:	POL.01	VPOL.0819	PPPC.12	OPP.01	ML.M4

PSC POLYGONAL TOOLING SYSTEM

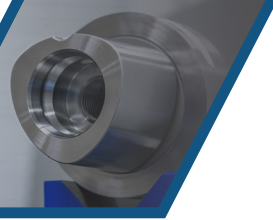

TURNING TOOL HOLDERS - MULTI-FUNCTIONAL

Wedge clamp
Direct coolant supply

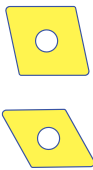
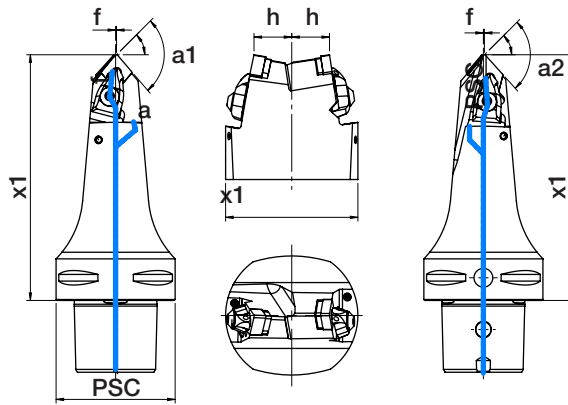

Size	Part Number	Orientation	Insert	PSC	a	a1	x1	f	h
C5	C5-T-DCM12DDM15-115CP	Left	CNM..1204/DNM..1506	50	95°	93°	115	0.5	20
C6	C6-T-DCM12DDM15-105CP	Left	CNM..1204/DNM..1506	63	95°	93°	105	0.5	20
	C6-T-DCM12DDM15-130CP	Left	CNM..1204/DNM..1506	63	95°	93°	130	0.5	20

	Clamp	Clamp Screw	Shim	Shim	Shim Screw	O-Ring Set	Nozzle
Spare Parts							
Part #:	SPKR or SPKL	VPA.0620.DC	PPPC.12	PPPD.15	VPP.0512.KG	OR.VPA.DC	ML.M4

PSC POLYGONAL TOOLING SYSTEM

TURNING TOOL HOLDERS - EXTERNAL

Wedge Clamp
Direct Coolant Supply

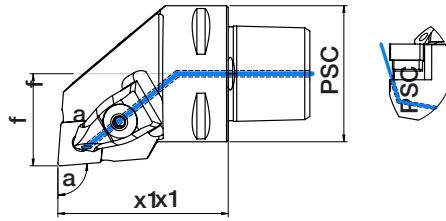

Size	Part Number	Orientation	Insert	PSC	a	x1	f
C4	C4-DCLNR-27050-12CP	Right	CNM..1204..	40	95°	50	27
	C4-DCLNL-27050-12CP	Left	CNM..1204..	40	95°	50	27
C5	C5-DCLNR-35060-12CP	Right	CNM..1204..	50	95°	60	35
	C5-DCLNL-35060-12CP	Left	CNM..1204..	50	95°	60	35
C6	C6-DCLNR-45065-12CP	Right	CNM..1204..	63	95°	65	45
	C6-DCLNL-45065-12CP	Left	CNM..1204..	63	95°	65	45
C8	C8-DCLNR-55080-12CP	Right	CNM..1204..	80	95°	80	55
	C8-DCLNL-55080-12CP	Left	CNM..1204..	80	95°	80	55

	Clamp	Clamp Screw	Shim	Shim Screw	O-Ring Set
Spare Parts					
Part #:	SPKR or SPKL	VPA.0620.DC	PPPC.12	VPP.0512.KG	OR.VPA.DC

PSC POLYGONAL TOOLING SYSTEM

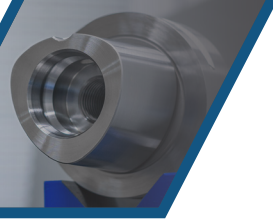





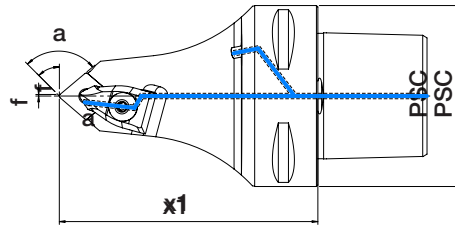

TURNING TOOL HOLDERS - EXTERNAL

Wedge Clamp
Direct Coolant Supply



Size	Part Number	Orientation	Insert	PSC	a	x1	f
C5	C5-DCMNN-00105-12CP	Neutral	CNM..1204..	50	95°	105	0
C6	C6-DCMNN-00090-12CP	Neutral	CNM..1204..	63	95°	90	0
	C6-DCMNN-00115-12CP	Neutral	CNM..1204..	63	95°	115	0

	Clamp	Clamp Screw	Shim	Shim Screw	O-Ring Set	Nozzle
Spare Parts						
Part #:	SPKR or SPKL	VPA.0620.DC	PPPC.12	VPP.0512.KG	OR.VPA.DC	ML.M10

PSC POLYGONAL TOOLING SYSTEM

TURNING TOOL HOLDERS - EXTERNAL

Wedge Clamp
Direct Coolant Supply

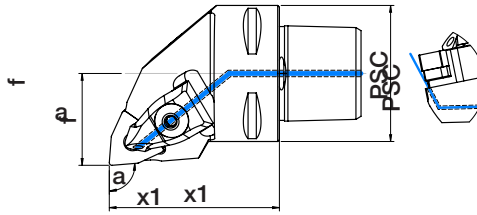

Size	Part Number	Orientation	Insert	PSC	a	x1	f
C4	C4-DWLNLR-27050-08CP	Right	WN..0804..	40	95°	50	27
	C4-DWLNL-27050-08CP	Left	WN..0804..	40	95°	50	27
C5	C5-DWLNLR-35060-08CP	Right	WN..0804..	50	95°	60	35
	C5-DWLNL-35060-08CP	Left	WN..0804..	50	95°	60	35
C6	C6-DWLNLR-45065-08CP	Right	WN..0804..	63	95°	65	45
	C6-DWLNL-45065-08CP	Left	WN..0804..	63	95°	65	45
C8	C8-DWLNLR-55080-08CP	Right	WN..0804..	80	95°	80	55
	C8-DWLNL-55080-08CP	Left	WN..0804..	80	95°	80	55

	Clamp	Clamp Screw	Shim	Shim Screw	O-Ring Set
Spare Parts					
Part #:	SPKR or SPKL	VPA.0620.DC	PPPW.08	VPP.0512.KG	OR.VPA.DC

PSC POLYGONAL TOOLING SYSTEM

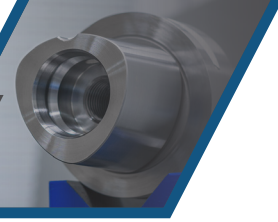

TURNING TOOL HOLDERS - EXTERNAL

Wedge Clamp
Direct Coolant Supply

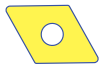
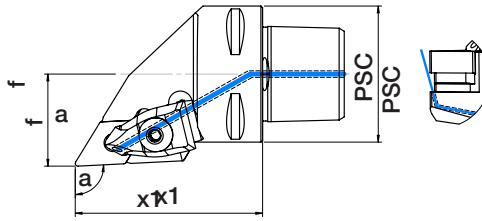

Size	Part Number	Orientation	Insert	PSC	a	x1	f
C4	C4-DDJNR-27055-15CP	Right	DN..1504..	40	93°	55	27
	C4-DDJNL-27055-15CP	Left	DN..1504..	40	93°	55	27
C5	C5-DDJNR-35060-15CP	Right	DN..1504..	50	93°	60	35
	C5-DDJNL-35060-15CP	Left	DN..1504..	50	93°	60	35
C6	C6-DDJNR-45065-15CP	Right	DN..1504..	63	93°	65	45
	C6-DDJNL-45065-15CP	Left	DN..1504..	63	93°	65	45
C8	C8-DDJNR-55080-15CP	Right	DN..1504..	80	93°	80	55
	C8-DDJNL-55080-15CP	Left	DN..1504..	80	93°	80	55

	Clamp	Clamp Screw	Shim	Shim Screw	O-Ring Set
Spare Parts					
Part #:	SPKR or SPKL	VPA.0620.DC	PPPD.15	VPP.0512.KG	OR.VPA.DC

PSC POLYGONAL TOOLING SYSTEM

TURNING TOOL HOLDERS - EXTERNAL

Wedge Clamp
Direct Coolant Supply

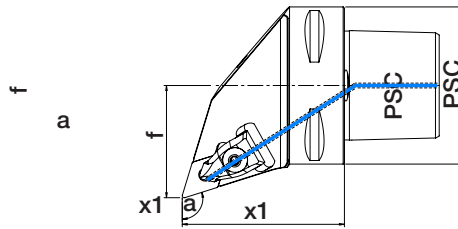

Size	Part Number	Orientation	Insert	PSC	a	x1	f
C4	C4-DDHNR-27055-15CP	Right	DNM..1506..	40	107.5°	55	27
	C4-DDHNL-27055-15CP	Left	DNM..1506..	40	107.5°	55	27
C5	C5-DDHNR-35060-15CP	Right	DNM..1506..	50	107.5°	60	35
	C5-DDHNL-35060-15CP	Left	DNM..1506..	50	107.5°	60	35
C6	C6-DDHNR-45065-15CP	Right	DNM..1506..	63	107.5°	65	45
	C6-DDHNL-45065-15CP	Left	DNM..1506..	63	107.5°	65	45

	Clamp	Clamp Screw	Shim	Shim Screw	O-Ring Set
Spare Parts					
Part #:	SPKR or SPKL	VPA.0620.DC	PPPD.15	VPP.0512.KG	OR.VPA.DC

PSC POLYGONAL TOOLING SYSTEM

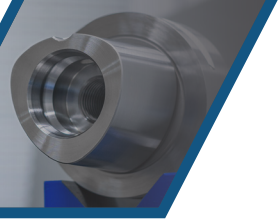

TURNING TOOL HOLDERS - EXTERNAL

Wedge Clamp
Direct Coolant Supply

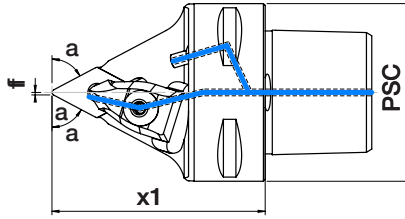

Size	Part Number	Orientation	Insert	PSC	a	x1	f
C4	C4-DDNNN-00055-15CP	Neutral	DNM..1506..	40	62.5°	55	0.5
C5	C5-DDNNN-00060-15CP	Neutral	DNM..1506..	50	62.5°	60	0.5
C6	C6-DDNNN-00065-15CP	Neutral	DNM..1506..	63	62.5°	65	0.5
C8	C8-DDNNN-00080-15CP	Neutral	DNM..1506..	80	62.5°	80	0.5

	Clamp	Clamp Screw	Shim	Shim Screw	Nozzle	Spring
Spare Parts						
Part #:	SPK	VPA.0520	PPPD.15 PPPD.15-T if using DNM..1504..	VPP.0512.KG	ML.M10	OPP.02

TURNING TOOL HOLDERS - EXTERNAL

Wedge Clamp
Direct Coolant Supply

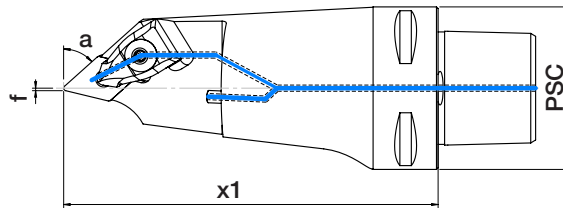

Size	Part Number	Orientation	Insert	PSC	a	x1	f
C5	C5-DDMNL-00115-15CP	Left	DNM..1506..	50	48°	115	1
C6	C6-DDMNL-33120-15CP	Left	DNM..1506..	63	48°	120	33
C8	C8-DDMNL-00160-15CP	Left	DNM..1506..	80	48°	160	1

	Clamp	Clamp Screw	Shim	Shim Screw	Nozzle	Spring
Spare Parts						
Part #:	SPK	VPA.0520	PPPD.15 PPPD.15-T if using DNM..1504..	VPP.0512.KG	ML.M10	OPP.02

PSC POLYGONAL TOOLING SYSTEM

TURNING TOOL HOLDERS - EXTERNAL

Wedge Clamp
Direct Coolant Supply

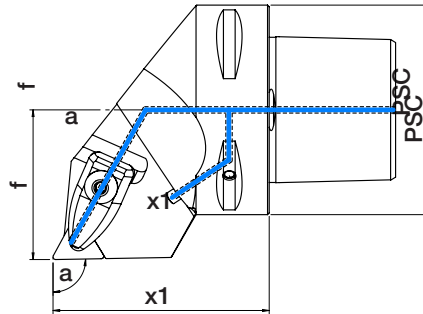

Size	Part Number	Orientation	Insert	PSC	a	x1	f
C4	C4-DTGNR-27050-16CP	Right	TNM..1604..	40	91°	50	27
	C4-DTGNL-27050-16CP	Left	TNM..1604..	40	91°	50	27
C5	C5-DTGNR-35060-16CP	Right	TNM..1604..	50	91°	60	35
	C5-DTGNL-35060-16CP	Left	TNM..1604..	50	91°	60	35
C6	C6-DTGNR-45065-16CP	Right	TNM..1604..	63	91°	65	45
	C6-DTGNL-45065-16CP	Left	TNM..1604..	63	91°	65	45

	Clamp	Clamp Screw	Shim	Shim Screw	O-Ring Set	Nozzle
Spare Parts						
Part #:	SPDR or SPDL	VPA.0620.DC	PPPT.16	VPP.0512.KG	OR.VPA.DC	ML.M08 for C4 and ML.M10 for C5, C6

PSC POLYGONAL TOOLING SYSTEM

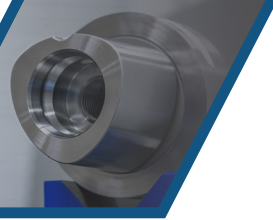

TURNING TOOL HOLDERS - EXTERNAL

Wedge Clamp
Direct Coolant Supply

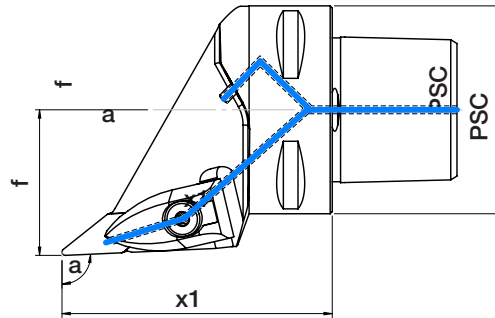

Size	Part Number	Orientation	Insert	PSC	a	x1	f
C4	C4-DVJNR-27062-16CP	Right	VN..1604..	40	93°	62	27
	C4-DVJNL-27062-16CP	Left	VN..1604..	40	93°	62	27
C5	C5-DVJNR-35065-16CP	Right	VN..1604..	50	93°	65	35
	C5-DVJNL-35065-16CP	Left	VN..1604..	50	93°	65	35
C6	C6-DVJNR-45065-16CP	Right	VN..1604..	63	93°	65	45
	C6-DVJNL-45065-16CP	Left	VN..1604..	63	93°	65	45
C8	C8-DVJNR-55080-16CP	Right	VN..1604..	80	93°	80	55
	C8-DVJNL-55080-16CP	Left	VN..1604..	80	93°	80	55

	Clamp	Clamp Screw	Shim	Shim Screw	Nozzle	Spring
Spare Parts						
Part #:	SPDL or SPDR	VPA.0520	PPPV.16	VPP.0512.RG	ML.M10	OPP.02

PSC POLYGONAL TOOLING SYSTEM

TURNING TOOL HOLDERS - EXTERNAL

Wedge Clamp
Direct Coolant Supply

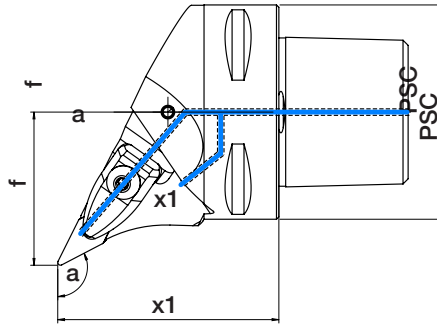

Size	Part Number	Orientation	Insert	PSC	a	x1	f
C4	C4-DVPCR-27062-16CP	Right	VNM..1604..	40	118°	62	27
	C4.DVPLN.27062.16CP	Left	VNM..1604..	40	118°	62	27
C5	C5-DVPCR-35060-16CP	Right	VNM..1604..	50	118°	60	35
	C5-DVPLN-35060-16CP	Left	VNM..1604..	50	118°	60	35
C6	C6-DVPCR-45065-16CP	Right	VNM..1604..	63	118°	65	45
	C6-DVPLN-45065-16CP	Left	VNM..1604..	63	118°	65	45

	Clamp	Clamp Screw	Shim	Shim Screw	Nozzle
Spare Parts					
Part #:	SPDR or SPDL	VPA.0620.DC	PPPV.16	VPP.0512.RG	ML.M08 for C4 and ML.M10 for C5, C6

PSC POLYGONAL TOOLING SYSTEM

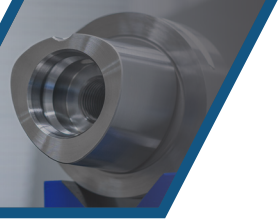

TURNING TOOL HOLDERS - EXTERNAL

Wedge Clamp
Direct Coolant Supply

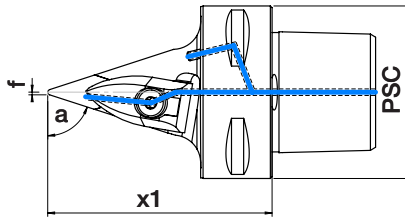

Size	Part Number	Orientation	Insert	PSC	a	x1	f
C4	C4-DVVNN-00062-16CP	Neutral	VN..1604..	40	72.5°	62	0
C5	C5-DVVNN-00065-16CP	Neutral	VN..1604..	50	72.5°	65	0
C6	C6-DVVNN-00065-16CP	Neutral	VN..1604..	63	72.5°	65	0
C8	C8-DVVNN-00080-16CP	Neutral	VN..1604..	80	72.5°	80	0

	Clamp	Clamp Screw	Shim	Shim Screw	Nozzle	Spring
Spare Parts						
Part #:	SPDL or SPDR	VPA.0520	PPPV.16	VPP.0512.RG	ML.M10	OPP.02

TURNING TOOL HOLDERS - EXTERNAL

Wedge Clamp
Direct Coolant Supply

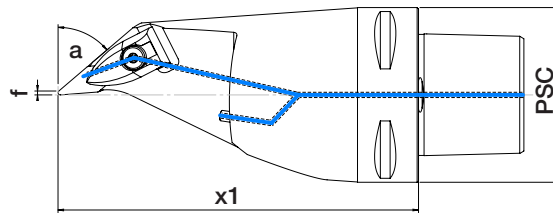

Size	Part Number	Orientation	Insert	PSC	a	x1	f
C6	C6-DVMNL-00130-16CP	Left	VN..1604..	63	50°	130	1.2
C8	C8-DVMNL-00160-16CP	Left	VN..1604..	80	50°	160	1.2

	Clamp	Clamp Screw	Shim	Shim Screw	Nozzle	Spring
Spare Parts						
Part #:	SPDL or SPDR	VPA.0520	PPPV.16	VPP.0512.RG	ML.M10	OPP.02

PSC POLYGONAL TOOLING SYSTEM

TURNING TOOL HOLDERS - EXTERNAL

Lever-Lock Clamp
Direct Coolant Supply

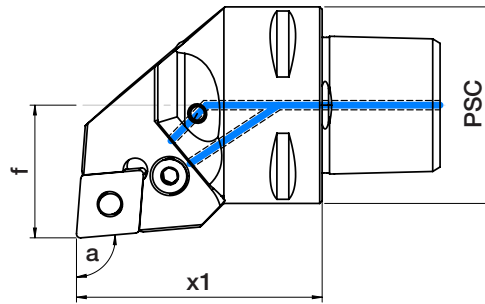

Size	Part Number	Orientation	Insert	PSC	a	x1	f
C4	C4-PCLNR-27050-12CP	Right	CN..1204..	40	95°	50	27
	C4-PCLNL-27050-12CP	Left	CN..1204..	40	95°	50	27
C5	C5-PCLNR-35060-12CP	Right	CN..1204..	50	95°	60	35
	C5-PCLNL-35060-12CP	Left	CN..1204..	50	95°	60	35
C6	C6-PCLNR-45065-12CP	Right	CN..1204..	63	95°	65	45
	C6-PCLNL-45065-12CP	Left	CN..1204..	63	95°	65	45
	C6-PCLNR-45165-12CP	Right	CN..1204..	63	95°	165	45
	C6-PCLNL-45165-12CP	Left	CN..1204..	63	95°	165	45

	Lever	Lever Screw	Shim	Shim Pin	Nozzle
Spare Parts					
Part #:	POL.01	VPOL.0819	PPPC.12	OPP.01	ML.M4

PSC POLYGONAL TOOLING SYSTEM

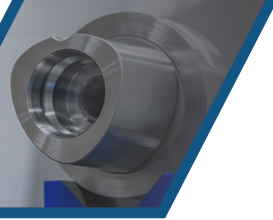



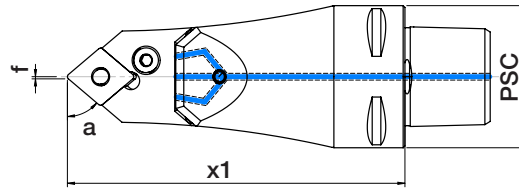

TURNING TOOL HOLDERS - EXTERNAL

Lever-Lock Clamp
Direct Coolant Supply



Size	Part Number	Orientation	Insert	PSC	a	x1	f
C4	C4-PCMNN-0095-12CP	Neutral	CN..1204..	40	50°	95	0
C5	C5-PCMNN-00115-12CP	Neutral	CN..1204..	50	50°	115	0
C6	C6-PCMNN-00115-12CP	Neutral	CN..1204..	63	50°	115	0
C8	C8-PCMNN-00150-12CP	Neutral	CN..1204..	80	50°	150	0

	Lever	Lever Screw	Shim	Shim Pin	Nozzle
Spare Parts					
Part #:	POL.01	VPOL.0819	PPPC.12	OPP.01	ML.M4

PSC POLYGONAL TOOLING SYSTEM

TURNING TOOL HOLDERS - EXTERNAL

Lever-Lock Clamp
Direct Coolant Supply

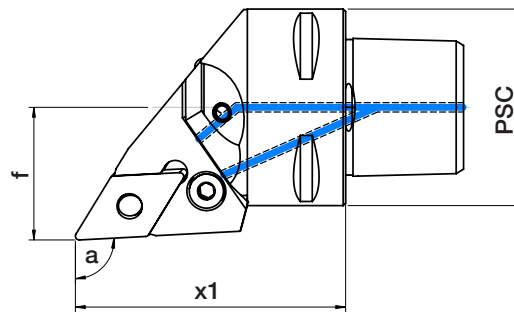

Size	Part Number	Orientation	Insert	PSC	a	x1	f
C4	C4-PDJNR-27050-15CP	Right	DNM..1506..	40	93°	55	27
	C4-PDJNL-27050-15CP	Left	DNM..1506..	40	93°	55	27
C5	C5-PDJNR-35060-15CP	Right	DNM..1506..	50	93°	60	35
	C5-PDJNL-35060-15CP	Left	DNM..1506..	50	93°	60	35
C6	C6-PDJNR-45065-15CP	Right	DNM..1506..	63	93°	65	45
	C6-PDJNL-45065-15CP	Left	DNM..1506..	63	93°	65	45
	C6-PDJNR-45165-15CP	Right	DNM..1506..	63	93°	165	45
	C6-PDJNL-45165-15CP	Left	DNM..1506..	63	93°	165	45
C8	C8-PDJNR-55080-15CP	Right	DNM..1506..	80	93°	80	55
	C8-PDJNL-55080-15CP	Left	DNM..1506..	80	93°	80	55

	Lever	Lever Screw	Shim	Shim Pin	Nozzle
Spare Parts					
Part #:	POL.02	VPOL.0819	PPPD.15 PPPD.15-T if using DNM..1504..	OPP.01	ML.M4

PSC POLYGONAL TOOLING SYSTEM

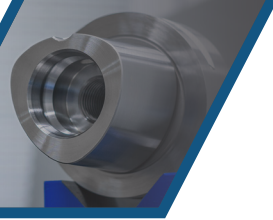

TURNING TOOL HOLDERS - EXTERNAL

Lever-Lock Clamp
Direct Coolant Supply

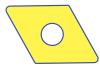
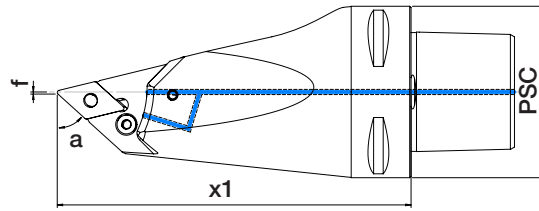

Size	Part Number	Orientation	Insert	PSC	a	x1	f
C6	C6-PDMNR-00130-15CP	Right	DNM..1506..	63	93°	130	0.6
	C6-PDMNL-00130-15CP	Left	DNM..1506..	63	93°	130	0.6

	Lever	Lever Screw	Shim	Shim Pin	Nozzle
Spare Parts					
Part #:	POL.02	VPOL.0819	PPPD.15 PPPD.15-T if using DNM..1504..	OPP.01	ML.M4

PSC POLYGONAL TOOLING SYSTEM

TURNING TOOL HOLDERS - EXTERNAL

Screw Clamp
Direct Coolant Supply

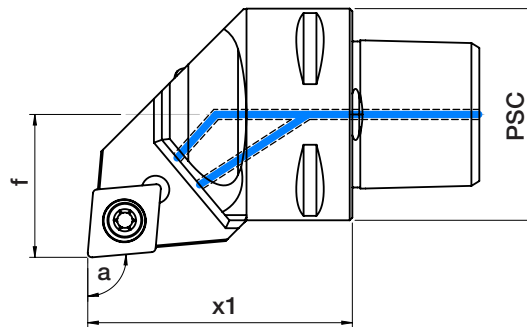

Size	Part Number	Orientation	Insert	PSC	a	x1	f
C4	C4-SCLCR-17090-12CP	Right	CCM..1204..	40	95°	90	17
	C4-SCLCL-17090-12CP	Left	CCM..1204..	40	95°	90	17
	C4-SCLCR-27050-12CP	Right	CCM..1204..	40	95°	50	27
	C4-SCLCL-27050-12CP	Left	CCM..1204..	40	95°	50	27
C5	C5-SCLCR-17090-12CP	Right	CCM..1204..	50	95°	90	17
	C5-SCLCL-17090-12CP	Left	CCM..1204..	50	95°	90	17
	C5-SCLCR-35060-12CP	Right	CCM..1204..	50	95°	60	35
	C5-SCLCL-35060-12CP	Left	CCM..1204..	50	95°	60	35
C6	C6-SCLCR-45065-12CP	Right	CCM..1204..	63	95°	65	45
	C6-SCLCL-45065-12CP	Left	CCM..1204..	63	95°	65	45

	Insert Screw	Shim	Shim Screw	Nozzle
Spare Parts				
Part #:	VPT.4516	PPVC.12	VPP.4513	ML.M4

TURNING TOOL HOLDERS - EXTERNAL

Screw Clamp
Direct Coolant Supply

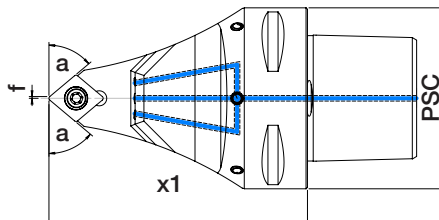

Size	Part Number	Orientation	Insert	PSC	a	x1	f
C6	C6-SCMCN-0090-12CP	Neutral	CCM..1204..	63	50°	90	0

	Insert Screw	Shim	Shim Screw	Nozzle
Spare Parts				
Part #:	VPT.4516	PPVC.12	VPP.4513	ML.M4

PSC POLYGONAL TOOLING SYSTEM

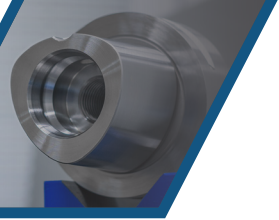

TURNING TOOL HOLDERS - EXTERNAL

Screw Clamp
Direct Coolant Supply

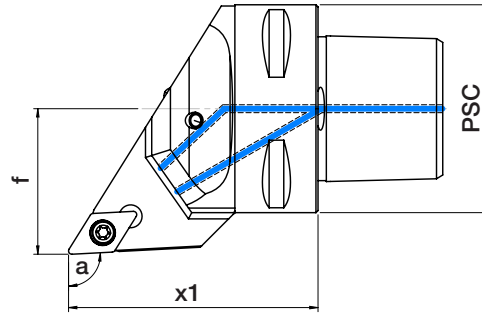

Size	Part Number	Orientation	Insert	PSC	a	x1	f
C4	C4-SDJCR-27050-11CP	Right	DCM..11T3..	40	93°	50	27
	C4-SDJCL-27050-11CP	Left	DCM..11T3..	40	93°	50	27
C5	C5-SDJCR-35060-11CP	Right	DCM..11T3..	50	93°	60	35
	C5-SDJCL-35060-11CP	Left	DCM..11T3..	50	93°	60	35
C6	C6-SDJCR-45065-11CP	Right	DCM..11T3..	63	93°	65	45
	C6-SDJCL-45065-11CP	Left	DCM..11T3..	63	93°	65	45

	Insert Screw	Shim	Shim Screw	Nozzle
Spare Parts				
Part #:	VPT.3514	PPVD.11	VPP.3511	ML.M4

TURNING TOOL HOLDERS - EXTERNAL

Screw Clamp
Direct Coolant Supply

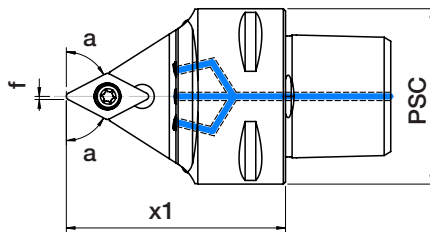

Size	Part Number	Orientation	Insert	PSC	a	x1	f
C4	C4-SDNCN-00050-11CP	Neutral	DCM..11T3..	40	62.5°	50	0
C5	C5-SDNCN-00060-11CP	Neutral	DCM..11T3..	50	62.5°	60	0

	Insert Screw	Shim	Shim Screw	Nozzle
Spare Parts				
Part #:	VPT.3514	PPVD.11	VPP.3511	ML.M4

PSC POLYGONAL TOOLING SYSTEM

TURNING TOOL HOLDERS - EXTERNAL

Screw Clamp
Direct Coolant Supply

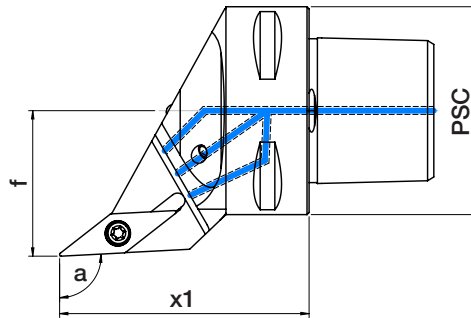

Size	Part Number	Orientation	Insert	PSC	a	x1	f
C4	C4-SVJBR-27050-16CP	Right	VB(VC)...1604..	40	93°	50	27
	C4-SVJBL-27050-16CP	Left	VB(VC)...1604..	40	93°	50	27
C5	C5-SVJBR-35060-16CP	Right	VB(VC)...1604..	50	93°	60	35
	C5-SVJBL-35060-16CP	Left	VB(VC)...1604..	50	93°	60	35
C6	C6-SVJBR-45065-16CP	Right	VB(VC)...1604..	63	93°	65	45
	C6-SVJBL-45065-16CP	Left	VB(VC)...1604..	63	93°	65	45

	Insert Screw	Shim	Shim Screw	Nozzle
Spare Parts				
Part #:	VPT.3508 (C4), VPT.3514 (C5, C6)	PPVV.16	VPP.3508	ML.M4

PSC POLYGONAL TOOLING SYSTEM

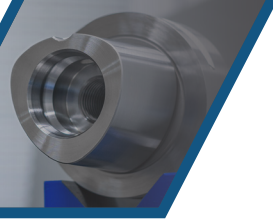

TURNING TOOL HOLDERS - EXTERNAL

Screw Clamp
Direct Coolant Supply

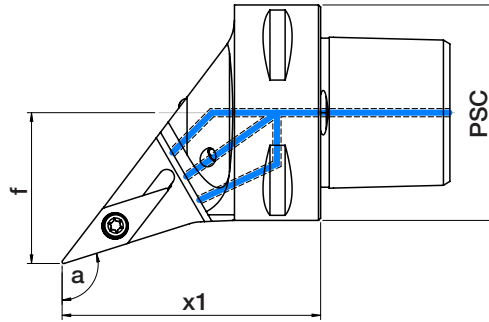

Size	Part Number	Orientation	Insert	PSC	a	x1	f
C4	C4-SVHBR-27050-16CP	Right	VB(VC)...1604..	40	107.5°	50	27
	C4-SVHBL-27050-16CP	Left	VB(VC)...1604..	40	107.5°	50	27
C5	C5-SVHBR-35060-16CP	Right	VB(VC)...1604..	50	107.5°	60	35
	C5-SVHBL-35060-16CP	Left	VB(VC)...1604..	50	107.5°	60	35
C6	C6-SVHBR-45065-16CP	Right	VB(VC)...1604..	63	107.5°	65	45
	C6-SVHBL-45065-16CP	Left	VB(VC)...1604..	63	107.5°	65	45

	Insert Screw	Shim	Shim Screw	Nozzle
Spare Parts				
Part #:	VPT.3514	PPVV.16	VPP.3511	ML.M4

PSC POLYGONAL TOOLING SYSTEM

TURNING TOOL HOLDERS - EXTERNAL

Screw Clamp
Direct Coolant Supply

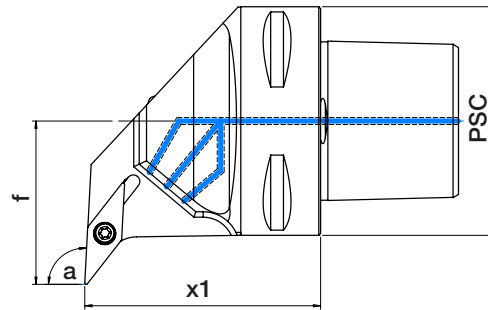

Size	Part Number	Orientation	Insert	PSC	a	x1	f
C6	C6-SVUBR-45065-16CP	Right	VB(VC)...1604..	63	93°	63	45
	C6-SVUBL-45065-16CP	Left	VB(VC)...1604..	63	93°	63	45

	Insert Screw	Shim	Shim Screw	Nozzle
Spare Parts				
Part #:	VPT.3514	PPVV.16	VPP.3511	ML.M4

TURNING TOOL HOLDERS - EXTERNAL

Screw Clamp
Direct Coolant Supply

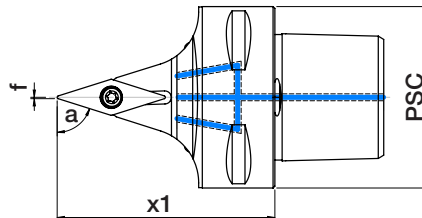

Size	Part Number	Orientation	Insert	PSC	a	x1	f
C4	C4-SVVBN-00055-16CP	Neutral	VB(VC)...1604..	40	72.5°	55	0
C5	C5-SVVBN-00060-16CP	Neutral	VB(VC)...1604..	50	72.5°	60	0
C6	C6-SVVBN-00065-16CP	Neutral	VB(VC)...1604..	63	72.5°	65	0

	Insert Screw	Shim	Shim Screw	Nozzle
Spare Parts				
Part #:	VPT.3514	PPVV.16	VPP.3511	ML.M4

PSC POLYGONAL TOOLING SYSTEM

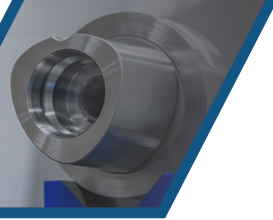



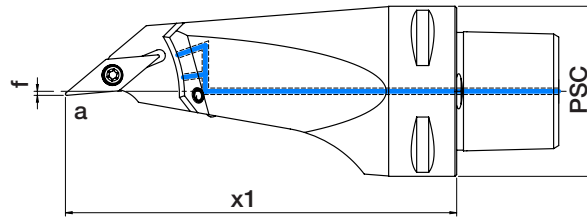

TURNING TOOL HOLDERS - EXTERNAL

Screw Clamp
Direct Coolant Supply



Size	Part Number	Orientation	Insert	PSC	a	x1	f
C5	C5-SVMBL-00115-16CP	Left	VB(VC)...1604..	50	95°	115	1.2
C6	C6-SVMBL-00130-16CP	Left	VB(VC)...1604..	63	95°	130	1.2
	C6-SVMBL-33120-16CP	Left	VB(VC)...1604..	63	95°	120	33

	Insert Screw	Shim	Shim Screw	Nozzle
Spare Parts				
Part #:	VPT.3514	PPVV.16	VPP.3511	ML.M4

PSC POLYGONAL TOOLING SYSTEM

TURNING TOOL HOLDERS - INTERNAL

Screw Clamp
Direct Coolant Supply

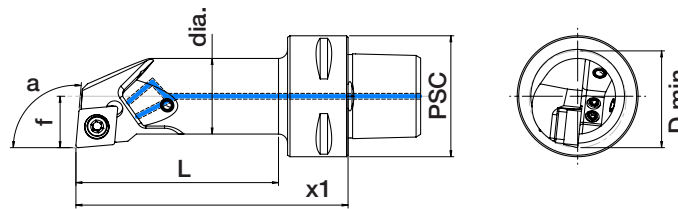

Size	Part Number	Orientation	Insert	PSC	a	x1	f	dia.	D min.	L
C4	C4-SCLCR-17090-12CP	Right	CCM..1204..	40	95°	50	17	25	32	69
	C4-SCLCL-17090-12CP	Left	CCM..1204..	40	95°	50	17	25	32	69
	C4-SCLCR-27050-12CP	Right	CCM..1204..	40	95°	50	27	N/A	N/A	N/A
	C4-SCLCL-27050-12CP	Left	CCM..1204..	40	95°	50	27	N/A	N/A	N/A
C5	C5-SCLCR-17090-12CP	Right	CCM..1204..	50	95°	90	17	25	32	67
	C5-SCLCL-17090-12CP	Left	CCM..1204..	50	95°	90	17	25	32	67
	C5-SCLCR-35060-12CP	Right	CCM..1204..	50	95°	60	35	N/A	N/A	N/A
	C5-SCLCL-35060-12CP	Left	CCM..1204..	50	95°	60	35	N/A	N/A	N/A
C6	C6-SCLCR-45065-12CP	Right	CCM..1204..	63	95°	65	45	N/A	N/A	N/A
	C6-SCLCL-45065-12CP	Left	CCM..1204..	63	95°	65	45	N/A	N/A	N/A

	Insert Screw	Shim	Shim Screw	Nozzle
Spare Parts				
Part #:	VPT.4512	PPVC.12	VPP.4508	ML.M4

TURNING TOOL HOLDERS - INTERNAL

Screw Clamp
Direct Coolant Supply

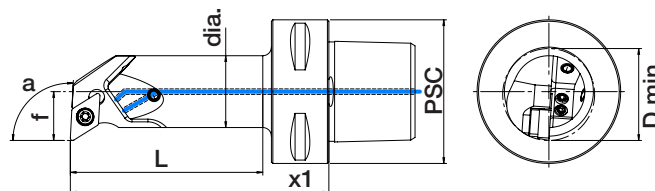

Size	Part Number	Orientation	Insert	PSC	a	x1	f	dia.	D min.	L
C4	C4-SDUCR-13080-11CP	Right	DCM..11T3..	40	93°	80	13	20	25	58
	C4-SDUCL-13080-11CP	Left	DCM..11T3..	40	93°	80	13	20	25	58
	C4-SDUCR-17090-11CP	Right	DCM..11T3..	40	93°	90	17	20	25	58
	C4-SDUCL-17090-11CP	Left	DCM..11T3..	40	93°	90	17	20	25	58
C5	C5-SDUCR-13080-11CP	Right	DCM..11T3..	50	93°	80	13	25	32	69
	C5-SDUCL-13080-11CP	Left	DCM..11T3..	50	93°	80	13	25	32	69
	C5-SDUCR-17090-11CP	Right	DCM..11T3..	50	93°	80	17	25	32	69
	C5-SDUCL-17090-11CP	Left	DCM..11T3..	50	93°	80	17	25	32	69

	Insert Screw	Shim	Shim Screw	Nozzle
Spare Parts				
Part #:	VPT.3511	PPVD.11	VPP.3508	ML.M4

PSC POLYGONAL TOOLING SYSTEM

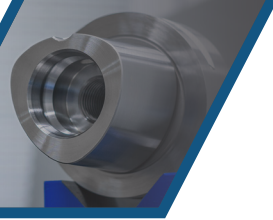



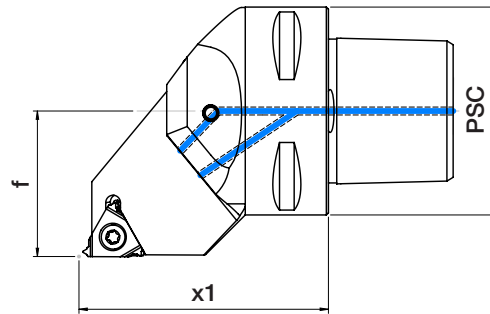

TURNING TOOL HOLDERS - EXTERNAL THREAD

Screw Clamp
Direct Coolant Supply



Size	Part Number	Orientation	Insert	PSC	x1	f
C4	C4-SER-27050-16CP	Right	16ER/L	40	50	27
	C4-SEL-27050-16CP	Left	16ER/L	40	50	27
C5	C5-SER-35060-16CP	Right	16ER/L	50	60	35
	C5-SEL-35060-16CP	Left	16ER/L	50	60	35
C6	C6-SER-45065-16CP	Right	16ER/L	63	65	45
	C6-SEL-45065-16CP	Left	16ER/L	63	65	45

	Insert Screw	Shim	Shim Screw	Nozzle
Spare Parts				
Part #:	VPT.3514	PPVN.16	VPP.3511	ML.M4

PSC POLYGONAL TOOLING SYSTEM

TURNING TOOL HOLDERS - INTERNAL THREAD

Screw Clamp
Direct Coolant Supply

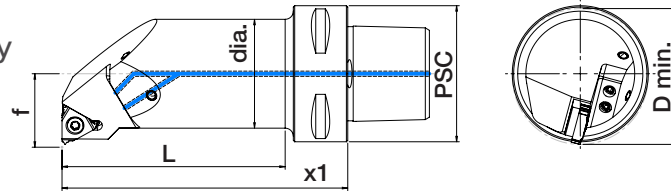

Size	Part Number	Orientation	Insert	PSC	x1	L	f	dia.	D min.
C4	C4-SIR-14060-16CP	Right	16IR/L	40	60	38	14	20	25
	C4-SIL-14060-16CP	Left	16IR/L	40	60	38	14	20	25
	C4-SIR-17070-16CP	Right	16IR/L	40	70	48	17	25	32
	C4-SIL-17070-16CP	Left	16IR/L	40	70	48	17	25	32
	C4-SIR-22090-16CP	Right	16IR/L	40	90	69	22	32	40
	C4-SIL-22090-16CP	Left	16IR/L	40	90	69	22	32	40
C5	C5-SIR-17070-16CP	Right	16IR/L	50	70	47	17	25	32
	C5-SIL-17070-16CP	Left	16IR/L	50	70	47	17	25	32
	C5-SIR-22090-16CP	Right	16IR/L	50	90	68	22	32	40
	C5-SIL-22090-16CP	Left	16IR/L	50	90	68	22	32	40
	C5-SIR-27105-16CP	Right	16IR/L	50	105	84	27	40	50
	C5-SIL-27105-16CP	Left	16IR/L	50	105	84	27	40	50
C6	C6-SIR-17075-16CP	Right	16IR/L	63	75	48	17	25	32
	C6-SIL-17075-16CP	Left	16IR/L	63	75	48	17	25	32
	C6-SIR-22090-16CP	Right	16IR/L	63	90	64	22	32	40
	C6-SIL-22090-16CP	Left	16IR/L	63	90	64	22	32	40
	C6-SIR-27105-16CP	Right	16IR/L	63	105	80	17	40	50
	C6-SIL-27105-16CP	Left	16IR/L	63	105	80	17	40	50

	Insert Screw	Shim	Shim Screw	Nozzle
Spare Parts				
Part #:	VPT.3514	PPVN.16	VPP.3511	ML.M4

PSC POLYGONAL TOOLING SYSTEM

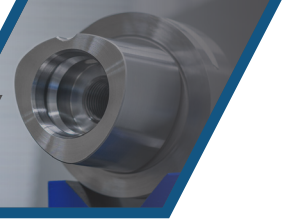

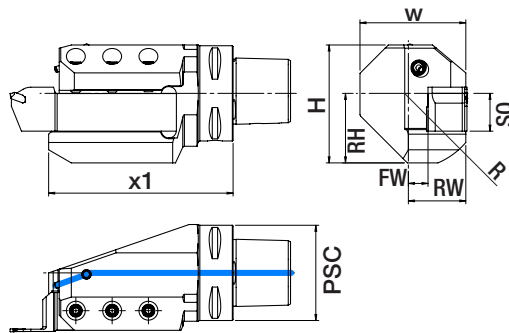

RECTANGULAR SHANK ADAPTERS

Internal Coolant Supply



Radial

Size	Part Number	Orientation	PSC	x1	SQ	H	W	RH	RW	FW	R	bar	kg
C5	C5-ASHR-095-19.05CP	Right	50	88	19.05	69	55.5	37	30	10.95	42.5	150	1.6
	C5-ASHL-095-19.05CP	Left	50	88	19.05	69	55.5	37	30	10.95	42.5	150	1.6
	C5-ASHR-095-20CP	Right	50	95	20	69	55.5	37	30	27	42.5	150	1.6
	C5-ASHL-095-20CP	Left	50	95	20	69	55.5	37	30	27	42.5	150	1.6
C6	C6-ASHR-105-19.05CP	Right	63	105	19.05	69	62	37	30	10.95	42.5	150	2.3
	C6-ASHL-105-19.05CP	Left	63	105	19.05	69	62	37	30	10.95	42.5	150	2.3
	C6-ASHR-105-20CP	Right	63	105	20	69	63.5	37	30	30	42.5	150	2.3
	C6-ASHL-105-20CP	Left	63	105	20	69	63.5	37	30	30	42.5	150	2.3
	C6-ASHR-122-25CP	Right	63	122	25	78	70	46	38	45	50	150	2.9
	C6-ASHL-122-25CP	Left	63	122	25	78	70	46	38	45	50	150	2.9
C8	C8-ASHR-122-25.4CP	Right	80	122	25.4	86	80	46	40	14.6	51	150	4.3
	C8-ASHL-122-25.4CP	Left	80	122	25.4	86	80	46	40	14.6	51	150	4.3

	Screw	Nozzle
Spare Parts		
Part #:	M10X1	ML.M10

PSC POLYGONAL TOOLING SYSTEM

RECTANGULAR SHANK ADAPTERS

Internal Coolant Supply

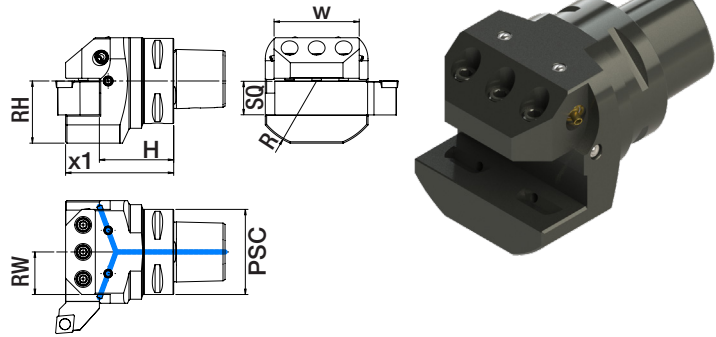

Axial

Size	Part Number	Orientation	PSC	x1	SQ	H	W	RW	R	bar	kg
C5	C5-ASHA-065-19.05CP	Right/Left	50	65	19.05	45.95	63	32	42.5	150	1.4
	C5-ASHA-065-20CP	Right/Left	50	65	20	45	63	32	42.5	150	1.4
C6	C6-ASHA-080-25.4CP	Right/Left	63	70	25	54.6	63	32	42.5	150	1.8
	C6-ASHA-080-25CP	Right/Left	63	70	25	55	63	32	42.5	150	1.8
C8	C8-ASHA-075-25.4CP	Right/Left	80	75	25.4	49.6	63	31.5	51	150	3.6

	Screw	Nozzle
Spare Parts		
Part #:	M10X1	ML.M10

RECTANGULAR SHANK ADAPTERS

Internal Coolant Supply

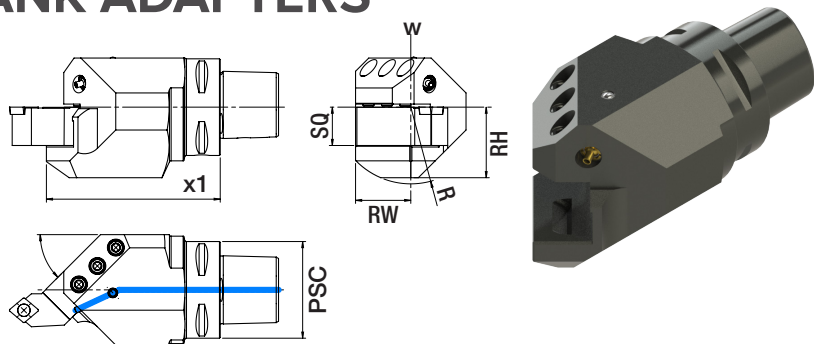

45°

Size	Part Number	Orientation	PSC	x1	SQ	RH	RW	R	bar	kg
C5	C5-ASHR-45-085-19.05CP	Right	50	85	19.05	37	32	42.5	150	1.6
	C5-ASHL-45-085-19.05CP	Left	50	85	19.05	37	32	42.5	150	1.6
	C5-ASHR-45-085-20CP	Right	50	85	20	37	32	42.5	150	1.6
	C5-ASHL-45-085-20CP	Left	50	85	20	37	32	42.5	150	1.6
C6	C6-ASHR-45-114-25CP	Right	63	114	25	46	36	50	150	2.2
	C6-ASHL-45-114-25CP	Left	63	114	25	46	36	50	150	2.2
	C6-ASHR-45-114-25.4CP	Right	63	114	25.4	46	36	50	150	2.2
	C6-ASHL-45-114-25.4CP	Left	63	114	25.4	46	36	50	150	2.2
C8	C8-ASHR-45-135-25.4CP	Right	80	135	25.4	46	40	55	150	6.8
	C8-ASHL-45-135-25.4CP	Left	80	135	25.4	46	40	55	150	6.8

	Screw	Nozzle
Spare Parts		
Part #:	M10X1	ML.M10

PSC POLYGONAL TOOLING SYSTEM

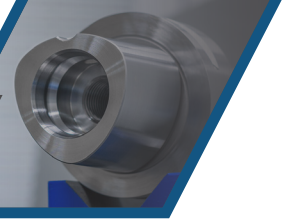

BORING BAR AND INDEXABLE DRILL HOLDERS

Direct Coolant Supply

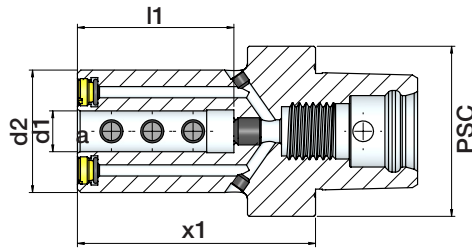

Size	Part Number	d1	PSC	x1	d2	l1
C4	C4-BBDH06-060CP	6	40	60	30	42
	C4-BBDH08-060CP	8	40	60	32	42
	C4-BBDH10-060CP	10	40	60	34	42
	C4-BBDH12-065CP	12	40	65	36	46
	C4-BBDH16-070CP	16	40	70	40	49
C5	C5-BBDH06-065CP	6	50	65	30	42
	C5-BBDH08-065CP	8	50	65	32	42
	C5-BBDH10-065CP	10	50	65	34	42
	C5-BBDH12-070CP	12	50	70	36	46
	C5-BBDH16-070CP	16	50	70	40	49
	C5-BBDH20-075CP	20	50	75	45	54
	C5-BBDH25-080CP	25	50	80	54	57
C6	C6-BBDH06-065CP	6	63	65	30	35
	C6-BBDH08-065CP	8	63	65	32	37
	C6-BBDH10-070CP	10	63	70	34	42
	C6-BBDH12-070CP	12	63	70	36	46
	C6-BBDH16-075CP	16	63	75	40	49
	C6-BBDH20-080CP	20	63	80	50	51
	C6-BBDH25-085CP	25	63	85	50	51
	C6-BBDH32-085CP	32	63	85	50	51
C8	C8-BBDH08-070CP	8	80	70	32	37
	C8-BBDH10-070CP	10	80	70	34	42
	C8-BBDH12-070CP	12	80	70	36	46
	C8-BBDH16-070CP	16	80	70	40	49
	C8-BBDH20-075CP	20	80	75	50	51
	C8-BBDH25-085CP	25	80	85	50	57

PSC POLYGONAL TOOLING SYSTEM

PSC REDUCTION HOLDERS

Internal Coolant Supply

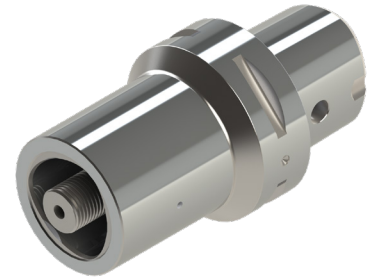
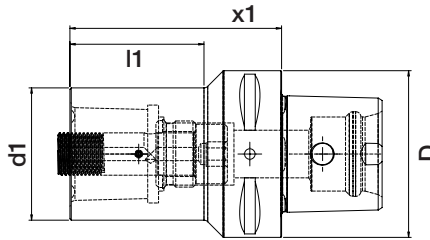

Size	Toolside Size	Part Number	D	d1	x1	l1
C4	C3	C4-RDC3-55	40	32	55	31
C5	C3	C5-RDC3-60	50	32	60	40
	C4	C5-RDC4-65	50	40	65	40
	C4	C5-RDC4-85	50	40	85	12
C6	C3	C6-RDC3-70	63	32	70	39
	C4	C6-RDC4-80	63	40	80	51
	C5	C6-RDC5-80	63	50	80	51
	C5	C6-RDC5-110	63	50	110	12
C8	C3	C8-RDC3-60	80	32	60	30
	C4	C8-RDC4-70	80	40	70	40
	C5	C8-RDC5-120	80	50	120	90
	C5	C8-RDC5-80	80	50	80	50
	C6	C8-RDC6-80	80	63	80	50

QUICK-CHANGE PSC REDUCTION HOLDERS

Internal Coolant Supply

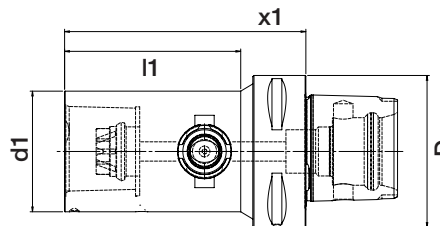

Size	Toolside Size	Part Number	D	d1	x1	l1	Max. RPM
C5	C4	C5-RDC4-85-QC	50	40	85	60.5	28,000
C6	C5	C6-RDCC5-100-QC	63	50	100	73	20,000
C8	C6	C8-RDC6-120-QC	80	63	120	84.5	14,000

PSC POLYGONAL TOOLING SYSTEM

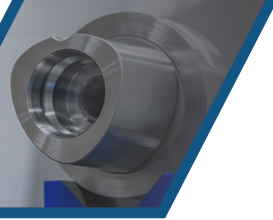

PSC EXTENSION HOLDERS

Internal Coolant Supply

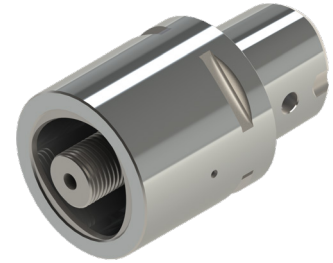
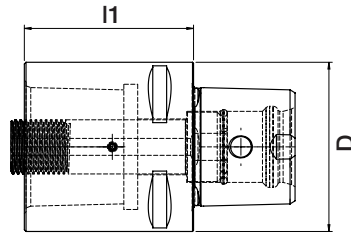

Size	Part Number	D	l1
C3	C3-EXC3-60	32	60
	C3-EXC3-80	32	80
C4	C4-EXC4-40	40	40
	C4-EXC4-60	40	60
	C4-EXC4-80	40	80
C5	C5-EXC5-50	50	50
	C5-EXC5-80	50	80
	C5-EXC5-100	50	100
C6	C6-EXC6-60	63	60
	C6-EXC6-100	63	100
	C6-EXC6-140	63	140
C8	C8-EXC8-65	80	65
	C8-EXC8-100	80	100
	C8-EXC8-125	80	125

QUICK-CHANGE PSC EXTENSION HOLDERS

Internal Coolant Supply

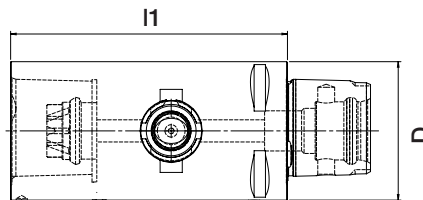

Size	Part Number	D	l1	Max RPM
C4	C4-EXC4-85-QC	40	85	39,000
C5	C5-EXC5-100-QC	50	100	28,000
C6	C6-EXC6-115-QC	63	115	20,000
C8	C8-EXC8-145-QC	80	145	14,000

PSC QUICK-CHANGE TOOLHOLDERS

Complete your transition to PSC toolholding with our PSC quick-change toolholders and take your machine's productivity to the next level.

- Single, double, Y, X, or double Y static holders
- Static holders for both OD or ID operation
- Driven tool holders - axial and radial
- Cylindrical shank tool holders and cut off holders
- Compatible with turrets of major machine tool builders

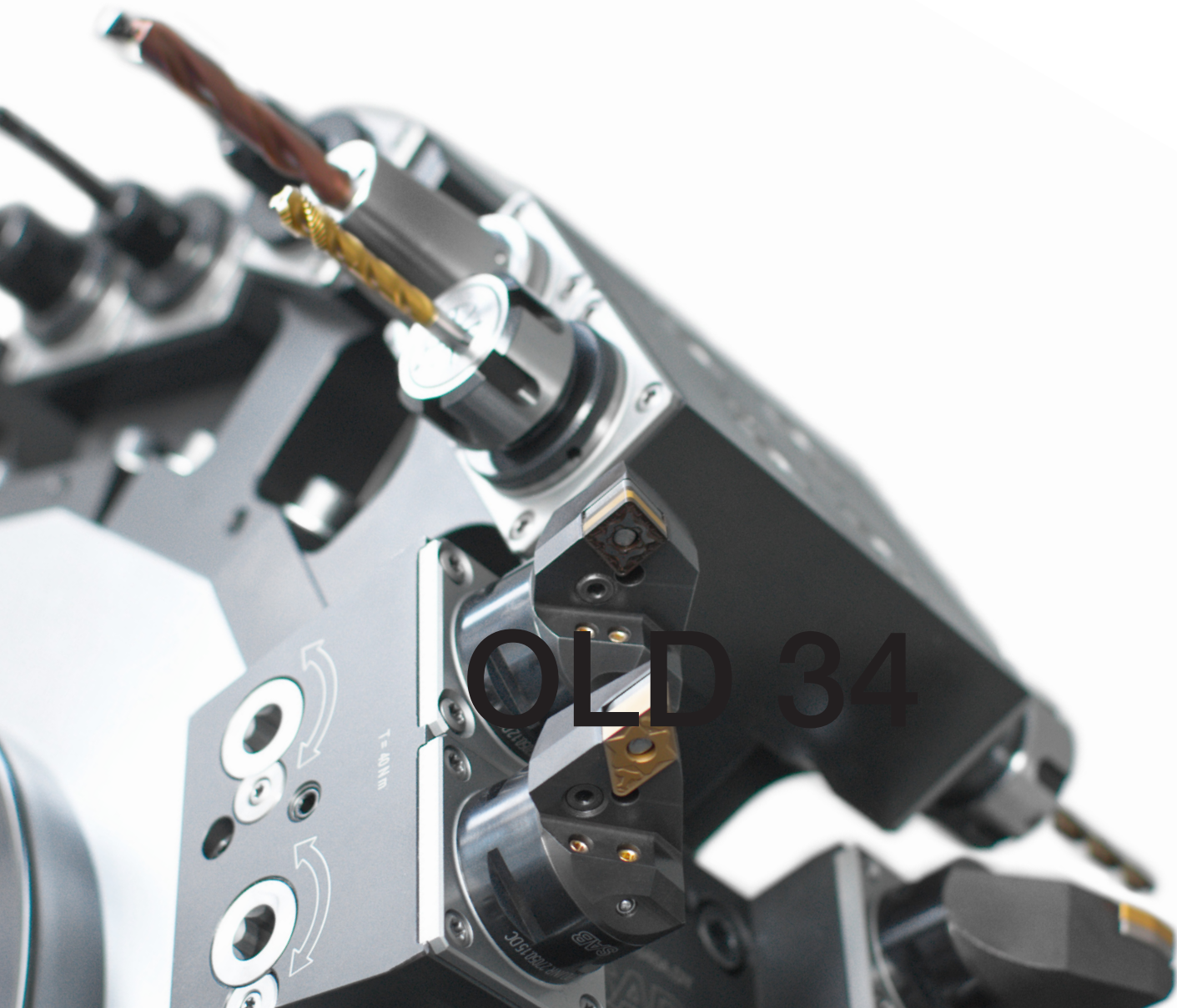

OLD 34

PSC POLYGONAL TOOLING SYSTEM

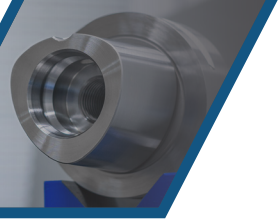

STATIC AND LIVE TOOLS FOR YOUR MACHINE

Engineered to increase the capabilities of a wide range of machines

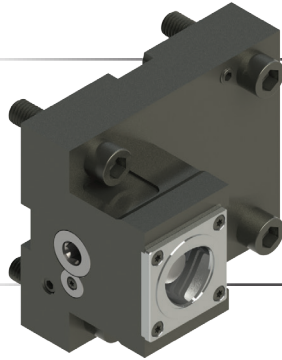

OD SINGLE HOLDER

- Right or left single OD quick coupling C4 holder

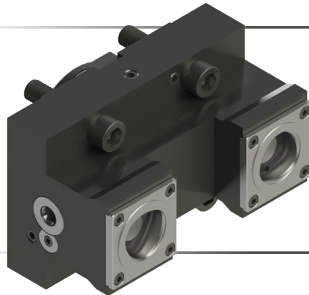

OD DOUBLE HOLDER

- Right or left double OD quick coupling C4 holder

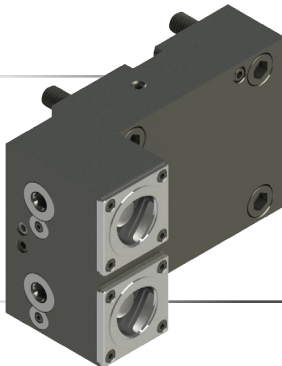

OD Y HOLDER

- Right or left Y-axis OD quick coupling C4 holder

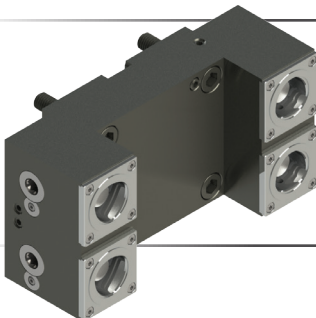

OD DOUBLE Y HOLDER

- Right or left double Y-axis OD quick coupling C4 holder

STATIC AND LIVE TOOLS FOR YOUR MACHINE

Engineered to increase the capabilities of a wide range of machines

ID SINGLE HOLDER

- Right or left single ID quick coupling C4 holder

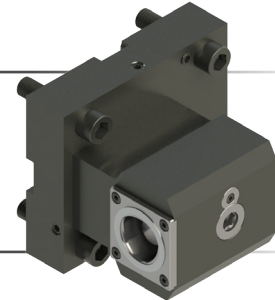

ID DOUBLE HOLDER

- Right or left double ID quick coupling C4 holder

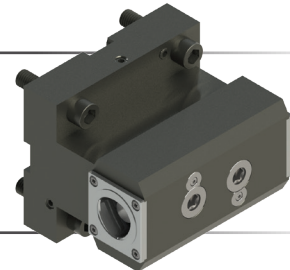

ID Y HOLDER

- Right or left Y-axis ID quick coupling C4 holder

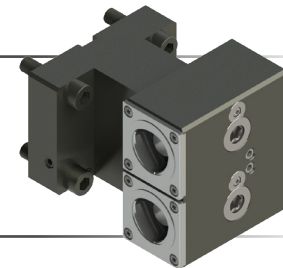

ID X HOLDER

- Right or left X-axis ID quick coupling C4 holder

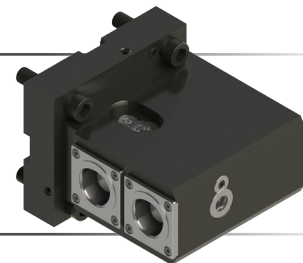

ID DOUBLE Y HOLDER

- Right or left double Y-axis OD quick coupling C4 holder

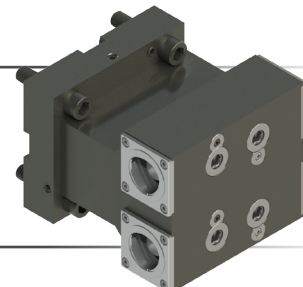

PSC POLYGONAL TOOLING SYSTEM

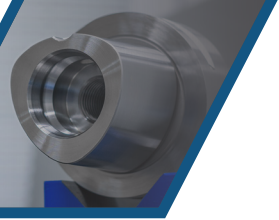

STATIC AND LIVE TOOLS FOR YOUR MACHINE

Engineered to increase the capabilities of a wide range of machines

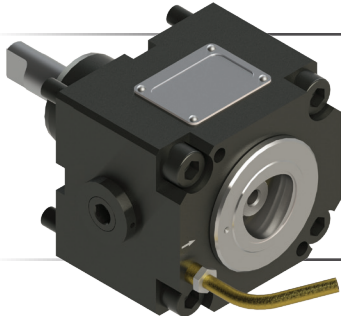

OD DRIVEN HOLDER

- OD drilling or milling unit, C4 quick-coupling

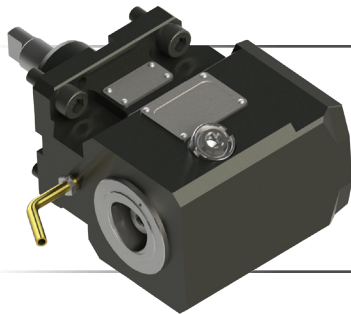

ID DRIVEN HOLDER

- ID drilling or milling unit, C4 quick-coupling

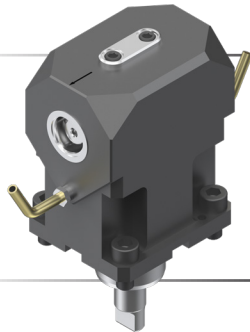

ID MAIN/SUB DRIVEN HOLDER

- ID Main/Sub drilling or milling unit, C3 quick-coupling

ER COLLET CHUCKS - SHORT ADAPTER

Internal Coolant Supply

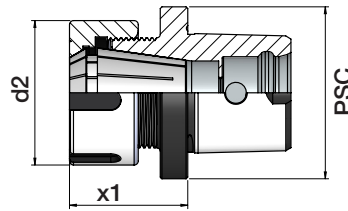

Size	Part Number	ER	PSC	x1	d2
C3	C3QC-ER16-030	ER16	32	30	28
	C3QC-ER20-035	ER20	32	35	35
	C3QC-ER25-044	ER25	32	44	42
C4	C4QC-ER20-032	ER20	40	32	35
	C4QC-ER25-035	ER25	40	35	42
	C4QC-ER32-052	ER32	40	52	50
C5	C5QC-ER25-034	ER25	50	34	42
	C5QC-ER32-041	ER32	50	41	50
	C5QC-ER40-058	ER40	50	58	63
C6	C6QC-ER32-042	ER32	63	42	50
	C6QC-ER40-048	ER40	63	48	63

PSC POLYGONAL TOOLING SYSTEM

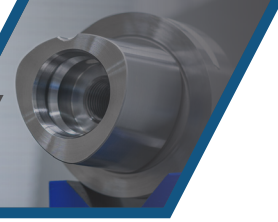

END MILL HOLDERS - SHORT ADAPTER

Internal Coolant Supply

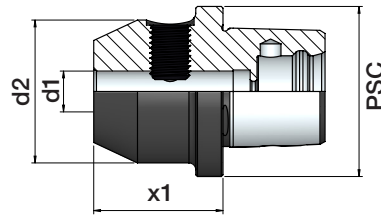

Size	Part Number	d1	PSC	x1	d2
C4	C4QC-0250-118	1/4"	40	30	20
	C4QC-0375-134	3/8"	40	34	25.4
	C4QC-0500-153	1/2"	40	39	35
	C4QC-0625-169	5/8"	40	43	38
	C4QC-0750-177	3/4"	40	45	45
C5	C5QC-0250-114	1/4"	50	29	20
	C5QC-0375-130	3/8"	50	33	25.4
	C5QC-0500-149	1/2"	50	38	35
	C5QC-0625-161	5/8"	50	41	38
	C5QC-0750-173	3/4"	50	44	45
C6	C6QC-0250-118	1/4"	63	30	20
	C6QC-0375-134	3/8"	63	34	25.4
	C6QC-0500-146	1/2"	63	37	35
	C6QC-0625-161	1/2"	63	41	38
	C6QC-0750-169	3/4"	63	43	45
	C6QC-1000-197	1"	63	50	57
	C6QC-1250-213	1.1/4"	63	54	63

Size	Part Number	d1	PSC	x1	d2
C3	C3QC-6-33	6	32	33	19
	C3QC-8-33	8	32	33	21
	C3QC-10-37	10	32	37	28
	C3QC-12-43	12	32	43	34
	C3QC-14-43	14	32	43	36
	C3QC-16-51	16	32	51	38
C4	C4QC-6-30	6	40	30	19
	C4QC-8-30	8	40	30	21
	C4QC-10-34	10	40	34	28
	C4QC-12-39	12	40	39	34
	C4QC-14-39	14	40	39	36
	C4QC-16-43	16	40	43	38
	C4QC-18-43	18	40	43	40
C4QC-20-45	20	40	45	45	
C5	C5QC-6-29	6	50	29	19
	C5QC-8-29	8	50	29	21
	C5QC-10-33	10	50	33	28
	C5QC-12-38	12	50	38	34
	C5QC-14-38	14	50	38	36
	C5QC-16-41	16	50	41	38
	C5QC-18-42	18	50	42	40
	C5QC-20-44	20	50	44	45
C5QC-25-50	25	50	50	51	
C6	C6QC-6-30	6	63	30	19
	C6QC-8-31	8	63	31	21
	C6QC-10-34	10	63	34	28
	C6QC-12-37	12	63	37	34
	C6QC-14-37	14	63	37	36
	C6QC-16-41	16	63	41	38
	C6QC-18-41	18	63	41	40
	C6QC-20-43	20	63	43	45
	C6QC-25-50	25	63	50	51
	C6QC-32-54	32	63	54	72

PSC POLYGONAL TOOLING SYSTEM

“3 IN 1” THERMO SHRINK-FIT CHUCKS - SHORT ADAPTERS

Internal and/or Direct
Coolant Supply

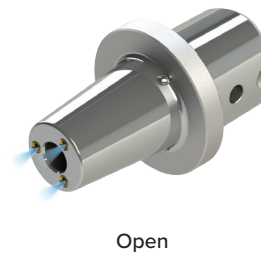
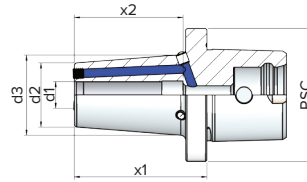

Open



High Speed

Closed

Size	Part Number	d1	PSC	x1	d2	d3	x2
C4	C4QC-SF0125-193	1/8"	40	49	9	15	41
	C4QC-SF0187-193	3/16"	40	49	10	16	41
	C4QC-SF0250-193CP	1/4"	40	49	20	26.2	41
	C4QC-SF0375-193CP	3/8"	40	49	24	30	41
	C4QC-SF0500-193CP	1/2"	40	49	24	30	41
	C4QC-SF0625-193CP	5/8"	40	49	27	33	41
C5	C5QC-SF0125-197	1/8"	50	50	9	15.2	42
	C5QC-SF0187-197	3/16"	50	50	10	16.2	42
	C5QC-SF0250-197CP	1/4"	50	50	20	26.3	42
	C5QC-SF0375-197CP	3/8"	50	50	24	30.3	42
	C5QC-SF0500-197CP	1/2"	50	50	24	30.3	42
	C5QC-SF0625-216CP	5/8"	50	55	27	34	47
C6	C6QC-SF0125-205	1/8"	63	52	9	15.5	44
	C6QC-SF0187-205	3/16"	63	52	10	16.5	44
	C6QC-SF0250-205CP	1/4"	63	52	20	26.6	44
	C6QC-SF0375-205CP	3/8"	63	52	24	30.6	44
	C6QC-SF0500-205CP	1/2"	63	52	24	30.6	44
	C6QC-SF0625-224CP	5/8"	63	57	27	34	49

Size	Part Number	d1	PSC	x1	d2	d3	x2
C3	C3QC-SF3-48	3	32	48	9	16	-
	C3QC-SF4-48	4	32	48	10	17	-
	C3QC-SF6-48	6	32	48	20	24.5	36
	C3QC-SF8-48	8	32	48	20	24.5	36
	C3QC-SF10-48	10	32	48	22.5	27	41
	C3QC-SF12-48	12	32	48	22.5	27	46
C4	C4QC-SF3-49	3	40	49	9	16	-
	C4QC-SF4-49	4	40	49	10	17	-
	C4QC-SF6-49	6	40	49	20	24.5	36
	C4QC-SF8-49	8	40	49	20	24.5	36
	C4QC-SF10-49	10	40	49	24	28.5	41
	C4QC-SF12-49	12	40	49	24	28.5	46
	C4QC-SF14-49	14	40	49	27	31.5	46
	C4QC-SF16-54	16	40	54	27	32.3	49
C5	C5QC-SF3-50	3	50	50	9	16	-
	C5QC-SF4-50	4	50	50	10	17	-
	C5QC-SF6-50	6	50	50	20	24.5	36
	C5QC-SF8-50	8	50	50	20	24.5	36
	C5QC-SF10-50	10	50	50	24	28.5	41
	C5QC-SF12-50	12	50	50	24	28.5	46
	C5QC-SF14-50	14	50	50	27	31.5	46
	C5QC-SF16-55	16	50	55	27	32.3	49
C6	C6QC-SF3-52	3	63	52	9	16	-
	C6QC-SF4-52	4	63	52	10	17	-
	C6QC-SF6-52	6	63	52	20	24.5	36
	C6QC-SF8-52	8	63	52	20	24.5	36
	C6QC-SF10-52	10	63	52	24	28.5	41
	C6QC-SF12-52	12	63	52	24	28.5	46
	C6QC-SF14-52	14	63	52	27	31.5	46
	C6QC-SF16-57	16	63	57	27	32.3	49

PSC POLYGONAL TOOLING SYSTEM

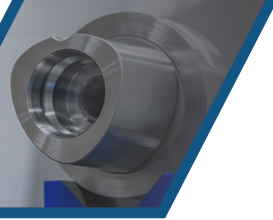

SHELL MILL HOLDERS - SHORT ADAPTERS

Internal Coolant Supply

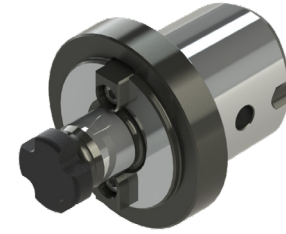
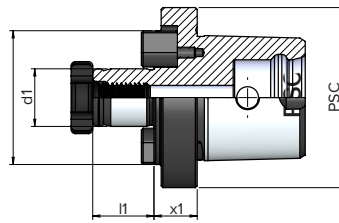

Size	Part Number	d1	PSC	x1	l1
C4	C4QC-SM0750-047	3/4"	40	12	17
C5	C5QC-SM0500-039	1/2"	50	10	14.5
	C5QC-SM0750-047	3/4"	50	12	17
	C5QC-SM1000-047	1"	50	12	17
	C5QC-SM1250-071	1.1/4"	50	18	17
C6	C6QC-SM0750-047	3/4"	63	12	17
	C6QC-SM1000-047	1"	63	12	17
	C6QC-SM1250-063	1.1/4"	63	16	17

Size	Part Number	d1	PSC	x1	l1
C3	C3QC-SM16-015	16	32	15	17
	C3QC-SM22-019	22	32	19	19
C4	C4QC-SM16-010	16	40	10	17
	C4QC-SM22-010	22	40	12	19
C5	C5QC-SM16-010	16	50	10	17
	C5QC-SM22-012	22	50	12	19
	C5QC-SM27-012	27	50	12	21
	C5QC-SM32-012	32	50	18	24
C6	C6QC-SM16-010	16	63	10	17
	C6QC-SM22-012	22	63	10	19
	C6QC-SM27-011	27	63	11	21
	C6QC-SM32-012	32	63	12	24

Achieve Exceptional Results and Gain a Competitive Edge

With High-Performance Solutions for Turning Centers

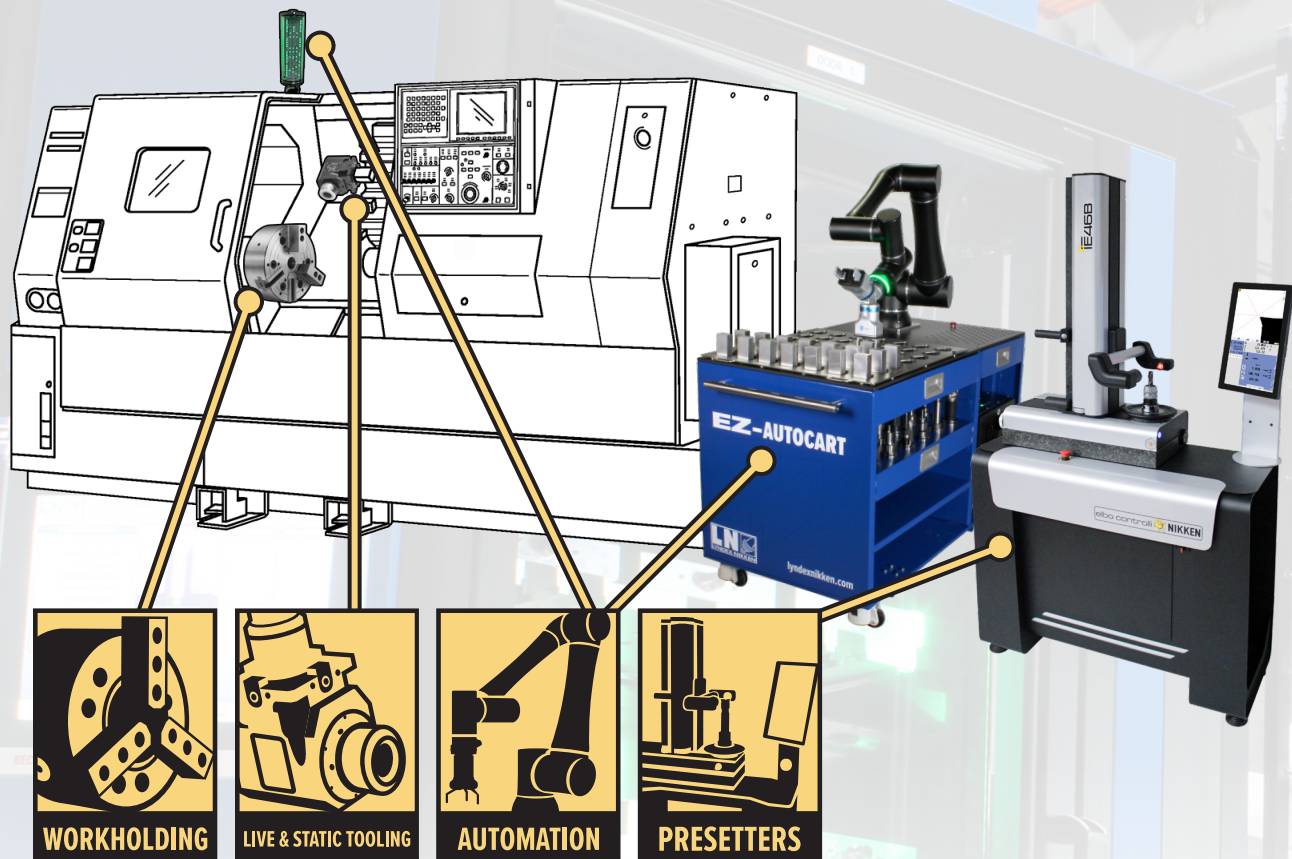

Maximize the potential of your turning operations with high-performance turning center accessories and automation. Engineered for exceptional results, our solutions significantly enhance your accuracy, efficiency, and productivity – driving significant improvements to your bottom line.

By partnering with Lyndex-Nikken, you can achieve high-performance results and gain a competitive edge in the market. Lyndex-Nikken is your partner in growth.

SCAN TO LEARN MORE



LYNDEX-NIKKEN PRODUCT LINE

Lyndex-Nikken's complete line of quality toolholders, rotary tables, presetters, machine tool accessories, and automation solutions help manufacturers improve their accuracy, efficiency, and productivity. Backed by over a half century of experience, Lyndex-Nikken sets the standard for high quality and innovative tooling and automation technology. Featuring advanced designs and rigid components, our machine tool accessories and automation solutions are built from the ground up for long-lasting precision, reliability, and productivity.

Manufacturers choose Lyndex-Nikken quality products for the machining results they get – and that gives them a competitive edge.

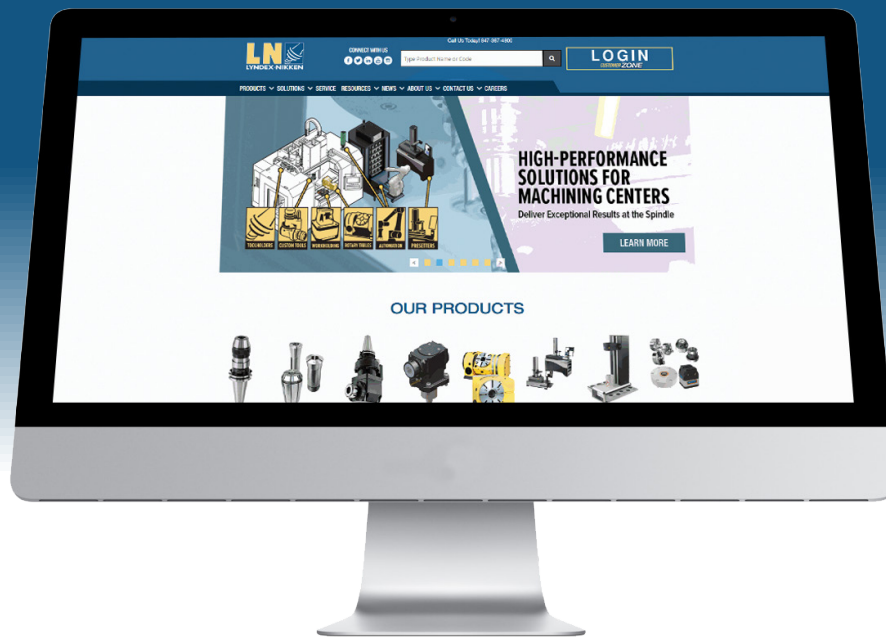
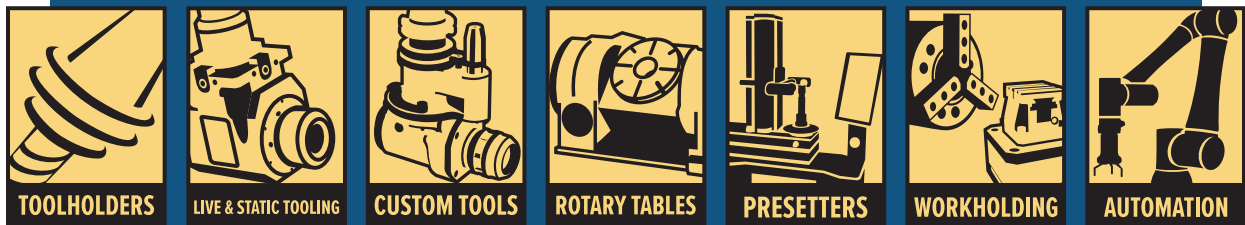

lyndexnikken.com

A photograph of the Lyndex-Nikken building facade, featuring the company name and logo in large letters above a glass entrance. The image is overlaid with a blue tint.

LYNDEX
NIKKEN

ABOUT US

At Lyndex-Nikken, we have made it our mission to provide the two most important points to keep you ahead of the competition: advanced technology and the innovation to keep it moving forward. In addition to manufacturing the highest quality machine tool accessories available on the market, our team of highly experienced technicians and product specialists offers unmatched customer service and engineering support to our customers worldwide.



1468 Armour Boulevard | Mundelein, IL 60060
Phone: 847.367.4800 | Fax: 847.367.4815 | sales@lyndexnikken.com
lyndexnikken.com

